

# Electronic Construction Collaboration System— Final Phase

**Final Report**  
**September 2014**

---

**IOWA STATE UNIVERSITY**  
**Institute for Transportation**

**Sponsored by**  
Iowa Department of Transportation  
Federal Highway Administration  
(InTrans Project 08-325)

## **About the Institute for Transportation**

The mission of the Institute for Transportation (InTrans) at Iowa State University is to develop and implement innovative methods, materials, and technologies for improving transportation efficiency, safety, reliability, and sustainability while improving the learning environment of students, faculty, and staff in transportation-related fields.

### **Disclaimer Notice**

The contents of this report reflect the views of the authors, who are responsible for the facts and the accuracy of the information presented herein. The opinions, findings and conclusions expressed in this publication are those of the authors and not necessarily those of the sponsors.

The sponsors assume no liability for the contents or use of the information contained in this document. This report does not constitute a standard, specification, or regulation.

The sponsors do not endorse products or manufacturers. Trademarks or manufacturers' names appear in this report only because they are considered essential to the objective of the document.

### **Iowa State University Non-Discrimination Statement**

Iowa State University does not discriminate on the basis of race, color, age, ethnicity, religion, national origin, pregnancy, sexual orientation, gender identity, genetic information, sex, marital status, disability, or status as a U.S. veteran. Inquiries regarding non-discrimination policies may be directed to Office of Equal Opportunity, Title IX/ADA Coordinator, and Affirmative Action Officer, 3350 Beardshear Hall, Ames, Iowa 50011, 515-294-7612, email [eooffice@iastate.edu](mailto:eooffice@iastate.edu).

### **Iowa Department of Transportation Statements**

Federal and state laws prohibit employment and/or public accommodation discrimination on the basis of age, color, creed, disability, gender identity, national origin, pregnancy, race, religion, sex, sexual orientation or veteran's status. If you believe you have been discriminated against, please contact the Iowa Civil Rights Commission at 800-457-4416 or the Iowa Department of Transportation affirmative action officer. If you need accommodations because of a disability to access the Iowa Department of Transportation's services, contact the agency's affirmative action officer at 800-262-0003.

The preparation of this report was financed in part through funds provided by the Iowa Department of Transportation through its "Second Revised Agreement for the Management of Research Conducted by Iowa State University for the Iowa Department of Transportation" and its amendments.

The opinions, findings, and conclusions expressed in this publication are those of the authors and not necessarily those of the Iowa Department of Transportation or the U.S. Department of Transportation.

**Technical Report Documentation Page**

<b>1. Report No.</b> Part of InTrans Project 08-325		<b>2. Government Accession No.</b>		<b>3. Recipient's Catalog No.</b>	
<b>4. Title and Subtitle</b> <b>Electronic Construction Collaboration System – Final Phase</b>				<b>5. Report Date</b> September 2014	
				<b>6. Performing Organization Code</b>	
<b>7. Author(s)</b> Jose A. Perez Reboredo and Charles T. Jahren				<b>8. Performing Organization Report No.</b> Part of InTrans Project 08-325	
<b>9. Performing Organization Name and Address</b> Institute for Transportation Iowa State University 2711 South Loop Drive, Suite 4700 Ames, IA 50010-8664				<b>10. Work Unit No. (TRAIS)</b>	
				<b>11. Contract or Grant No.</b>	
<b>12. Sponsoring Organization Name and Address</b> Iowa Department of Transportation 800 Lincoln Way Ames, IA 50010				<b>13. Type of Report and Period Covered</b> Final Report	
				<b>14. Sponsoring Agency Code</b> SPR RB02-008	
<b>15. Supplementary Notes</b> Visit <a href="http://www.intrans.iastate.edu">www.intrans.iastate.edu</a> for color PDF files of this and other research reports.					
<b>16. Abstract</b> <p>This phase of the research project involved two major efforts: (1) Complete the implementation of AEC-Sync (formerly known as Attolist) on the Iowa Falls Arch Bridge project and (2) develop a WPMS for projects under \$10 million.</p> <p>For the first major effort, AEC-Sync was provided for the Iowa DOT in a software as a service agreement, allowing the Iowa DOT to rapidly implement the solution with modest effort. During the 2010 fiscal year, the research team was able to help with the implementation process for the solution. The research team also collected feedback from the Broadway Viaduct project team members before the start of the project and implementation of the solution. For the 2011 fiscal year, the research team collected the post-project surveys from the Broadway Viaduct project members and compared them to the pre-project survey results. The result of the AEC-Sync implementation in the Broadway Viaduct project was a positive one. The project members were satisfied with the performance of AEC-Sync and how it facilitated document management and transparency. In addition, the research team distributed, collected, and analyzed the pre-project surveys for the Iowa Falls Arch Bridge project. During the 2012 fiscal year, the research team analyzed the post-project surveys for the Iowa Falls Arch Bridge project AEC-Sync implementation and found a positive outcome when compared to the pre-project surveys.</p> <p>The second major effort for this project involved the identification and implementation of a WPMS solution for smaller bridge and highway projects. During the 2011 fiscal year, Microsoft SharePoint was selected to be implemented on these smaller highway projects. In this year, workflows for the shop/working drawings for the smaller highway projects specified in Section 1105 of the Iowa DOT Specifications were developed. These workflows will serve as the guide for the development of the SharePoint pages. In order to implement the Microsoft SharePoint pages, the effort of an integrated team proved to be vital because it brought together the expertise required from researchers, programmers, and webpage developers to develop the SharePoint pages.</p>					
<b>17. Key Words</b> bridge—highway—WPMS—web-based-electronic collaboration				<b>18. Distribution Statement</b> No restrictions.	
<b>19. Security Classification (of this report)</b> Unclassified.		<b>20. Security Classification (of this page)</b> Unclassified.		<b>21. No. of Pages</b> 67	<b>22. Price</b> NA



# **ELECTRONIC CONSTRUCTION COLLABORATION SYSTEM – FINAL PHASE**

**Final Report  
September 2014**

**Principal Investigator**

Charles T. Jahren  
Professor, Civil, Construction and Environmental Engineering  
Institute for Transportation, Iowa State University

**Research Assistant**

Jose A. Perez Reboredo

**Authors**

Jose A. Perez Reboredo and Charles T. Jahren

Sponsored by  
the Iowa Department of Transportation  
and the Federal Highway Administration  
(SPR RB02-008)

Preparation of this report was financed in part  
through funds provided by the Iowa Department of Transportation  
through its Research Management Agreement with the  
Institute for Transportation  
(InTrans Project 08-325)

A report from  
**Institute for Transportation**  
**Iowa State University**  
2711 South Loop Drive, Suite 4700  
Ames, IA 50010-8664  
Phone: 515-294-8103  
Fax: 515-294-0467  
[www.intrans.iastate.edu](http://www.intrans.iastate.edu)



## TABLE OF CONTENTS

ACKNOWLEDGMENTS .....	ix
EXECUTIVE SUMMARY .....	xi
INTRODUCTION .....	1
Problem Statement .....	1
Research Objectives.....	1
AEC-SYNC IMPLEMENTATION.....	3
Overview.....	3
Iowa Falls Arch Bridge Project Post-Project Surveys .....	3
WORKFLOW DEVELOPMENT .....	7
Methodology.....	7
Results.....	9
Request for Information Workflow .....	10
Analysis.....	16
SHAREPOINT IMPLEMENTATION.....	17
Microsoft SharePoint and Project Initiation .....	19
Microsoft SharePoint throughout the Project’s Duration .....	19
LESSONS LEARNED AND CONCLUSIONS.....	22
APPENDIX A. IOWA FALLS ARCH BRIDGE PROJECT SURVEY RESULTS .....	A-1
APPENDIX B. SHOP/WORKING DRAWINGS WORKFLOWS FOR ACTIVITIES IN IOWA DOT SPECIFICATION SECTION 1105 .....	B-1
APPENDIX C. REQUEST FOR INFORMATION WORKFLOWS BY FRANCIS O. DAYAMBA.....	C-1
Method .....	C-2
Results.....	C-2
Limitations .....	C-3

## LIST OF FIGURES

Figure 1. Survey results – learning the system .....	4
Figure 2. Survey results – transparency of document management .....	5
Figure 3. Survey results – accountability of project participants.....	5
Figure 4. Survey results – project implementation size .....	6
Figure 5. Legend of symbols .....	9
Figure 6. Structural erection manual workflow .....	11
Figure 7. Workflow for the steel and aluminum pedestrian handrails.....	12
Figure 8. Cofferdam design workflow .....	13
Figure 9. Safety grates workflow .....	14
Figure 10. Temporary sheet pile retaining walls workflow .....	15
Figure 11. The SharePoint development team.....	18
Figure 12. SharePoint page initiation workflow .....	19
Figure 13. SharePoint project cycle .....	20
Figure A.1 Submittal process.....	A-1
Figure A.2. Usage per month.....	A-1
Figure A.3. RFI process .....	A-2
Figure A.4. Project Information.....	A-2
Figure A.5. Overall cost of document management .....	A-3
Figure A.6. Project role.....	A-3
Figure A.7. Computer and internet requirements .....	A-4
Figure A.8. Bridge project management.....	A-4
Figure B.1. Falsework for slab bridges workflow .....	B-1
Figure B.2. Cofferdam design workflow .....	B-2
Figure B.3. Reconstruction of substructure workflow.....	B-3
Figure B.4. Steel structures workflow .....	B-4
Figure B.5. Detail plans for falsework or centering support of steel structures workflow.....	B-5
Figure B.6. Steel and aluminum pedestrian handrails workflow .....	B-6
Figure B.7. Precast concrete workflow .....	B-7
Figure B.8. Tower lighting workflow .....	B-8
Figure B.9. Bridge components workflow.....	B-9
Figure B.10. Pre-engineered steel truss recreational trail bridge workflow .....	B-10
Figure B.11. Removal of box girder bridges workflow .....	B-11
Figure B.12. Structural erection manual workflow .....	B-12
Figure B.13. Temporary shoring workflow .....	B-13
Figure B.14. Temporary sheet pile retaining walls workflow .....	B-14
Figure B.15. Safety grates workflow .....	B-15
Figure B.16. Highway lighting workflow.....	B-16
Figure B.17. Highway signing steel breakaways posts workflow .....	B-17
Figure B.18. Traffic signalization workflow .....	B-18
Figure B.19. Highway signing–type B signs workflow.....	B-19
Figure B.20. MSE, segmental and modular block retaining walls workflow .....	B-20
Figure B.21. Soil nail and tie-back retaining walls workflow .....	B-21
Figure B.22. Intermediate foundation improvement workflow .....	B-22
Figure B.23. Highway sign support structures workflow .....	B-23



Figure C.1. RFI Workflow for the Iowa DOT .....C-5

**LIST OF TABLES**

Table 1. Shop/working drawings for Iowa DOT (Iowa DOT 2011) .....8  
Table C.1. Individuals involved in solving RFIs on two Iowa DOT projects .....C-3



## ACKNOWLEDGMENTS

The authors would like to thank the Iowa Department of Transportation for sponsoring this research and the Federal Highway Administration for state planning and research (SPR) funds used for this project. The authors would also like to thank everyone involved in the technical advisory committee (TAC) and any other meetings in relation to the current phase of the research project, especially the following people:

- Jim Nelson
- Kim Powell
- Karla Hocker
- Annette Jeffers
- Charles Lee
- Cherice Ogg
- Dennis Peperkorn
- James Hauber
- John Narigon
- John Smythe
- Kelly Popp
- Steven Meyer



## **EXECUTIVE SUMMARY**

Complexities in bridge projects caused a need for the Iowa Department of Transportation (Iowa DOT) to identify and implement a web-based project management system (WPMS) as part of its construction administration system. Throughout the various electronic collaboration project phases, the research team, alongside Iowa DOT staff, was able to identify and test solutions for various bridge projects. For the first project phase, the solution selected was an in-house website developed for document sharing. From this implementation, it was identified that a solution that had email notification capabilities was something more desirable. For this reason, the second phase of the research consisted of the implementation of a solution that had this feature: Google Groups along with an FTP site. At the end of the research phase, it was concluded that a more automated solution could be more beneficial.

This phase of the research project involved two major efforts: (1) Complete the implementation of AEC-Sync (formerly known as Attolist) on the Iowa Falls Arch Bridge project and (2) develop a WPMS for projects under \$10 million. These efforts are explained in more detail in the following paragraphs.

AEC-Sync was provided for the Iowa DOT in a software as a service agreement, allowing the Iowa DOT to rapidly implement the solution with modest effort. During the 2010 fiscal year, the research team was able to help with the implementation process for the solution. The research team also collected feedback from the Broadway Viaduct project team members before the start of the project and implementation of the solution. For the 2011 fiscal year, the research team collected the post-project surveys from the Broadway Viaduct project members and compared them to the pre-project survey results. The result of the AEC-Sync implementation in the Broadway Viaduct project was a positive one. The project members were satisfied with the performance of AEC-Sync and how it facilitated document management and transparency. In addition, the research team distributed, collected, and analyzed the pre-project surveys for the Iowa Falls Arch Bridge project. During the 2012 fiscal year, the team analyzed the post-project surveys for the Iowa Falls Arch Bridge project AEC-Sync implementation and found a positive outcome when compared to the pre-project surveys.

The second major effort for this project involved the identification and implementation of a WPMS solution for smaller bridge and highway projects. During the 2011 fiscal year, Microsoft SharePoint was selected to be implemented on these smaller highway projects. In this year, workflows for the shop/working drawings for the smaller highway projects specified in Section 1105 of the Iowa DOT Specifications were developed. These workflows will serve as the guide for the development of the SharePoint pages. In order to implement the Microsoft SharePoint pages, the effort of an integrated team proved to be vital because it brought together the expertise required from researchers, programmers, and webpage developers to develop the SharePoint pages.



## **INTRODUCTION**

### **Problem Statement**

Bridge construction projects are becoming more complex in terms of the project team composition, design aspects, and construction processes. Project teams are becoming more diverse in terms of their location (not centrally located) and team member compositions. Design aspects are becoming more complex due to code requirements and emphasis on the aesthetics of the bridge. Lastly, new construction methods such as lean and rapid accelerated bridge construction are becoming more common within the industry. In 2008 the Iowa Department of Transportation (Iowa DOT) was entering a phase of complex bridge construction, beginning with the I-80 bridge, the US 34 bridge over the Missouri River, and the I-74 bridge over the Mississippi River. Because of this, the Iowa DOT contacted the researchers to identify a web-based project management system (WPMS) that could ease the document management of shop drawings and requests for information (RFIs) for these projects.

For the first two phases of this research project, the team sought a WPMS that met the needs and requirements for large and complex bridge projects. The results of the implementation of a WPMS for these types of projects have proven to be positive. The researchers recommended to the Iowa DOT that a similar solution could also benefit smaller highway projects (less than \$10 million). The previous research phase studied several WPMS that could be implemented for these projects. It was expected that a WPMS would increase efficiency specifically for the shop drawing approval process for smaller highway projects. For this reason, the research team and the Iowa DOT selected Microsoft SharePoint, a web content management system, to be used for these smaller projects. For the current and final phase of the research project, the research team documented workflows for other Iowa DOT projects as stated in Section 1105 of the Iowa DOT Specifications. This project phase also consisted of developing and implementing the SharePoint pages for the smaller projects.

### **Research Objectives**

To study the implementation of a WPMS on complex bridge projects, the Iowa Falls Arch Bridge project's AEC-Sync (formerly known as Attolist) implementation was evaluated. The post-project surveys were distributed to the Iowa Falls Arch Bridge project members, and the results were analyzed by the research team.

Another objective that was involved in this research project was to document the workflows for the working and shop drawings referenced in Section 1105 of the Iowa DOT's Specifications (Iowa DOT 2011). Documenting these workflows will ease the implementation process of the selected WPMS solution, Microsoft SharePoint, in these types of projects. These workflows will provide an overall understanding to the Iowa DOT engineers of how the shop/working drawing process takes place. Understanding the workflows will also provide an opportunity to re-engineer some of the Iowa DOT's processes, if need be.

An additional objective was to develop the Microsoft SharePoint pages and begin implementing this WPMS. The research team undertook the task of documenting the process involved in the development and implementation of the solution.



## **AEC-SYNC IMPLEMENTATION**

### **Overview**

Work on the AEC-Sync implementation continued during the 2012 fiscal year. The post-project surveys were distributed to the Iowa Falls Arch Bridge project team members. These results were compared to the pre-project surveys in order to demonstrate how the WPMS implementation affected the project team's performance and opinions of the system.

### **Iowa Falls Arch Bridge Project Post-Project Surveys**

#### *Post-Project Survey Respondent Population*

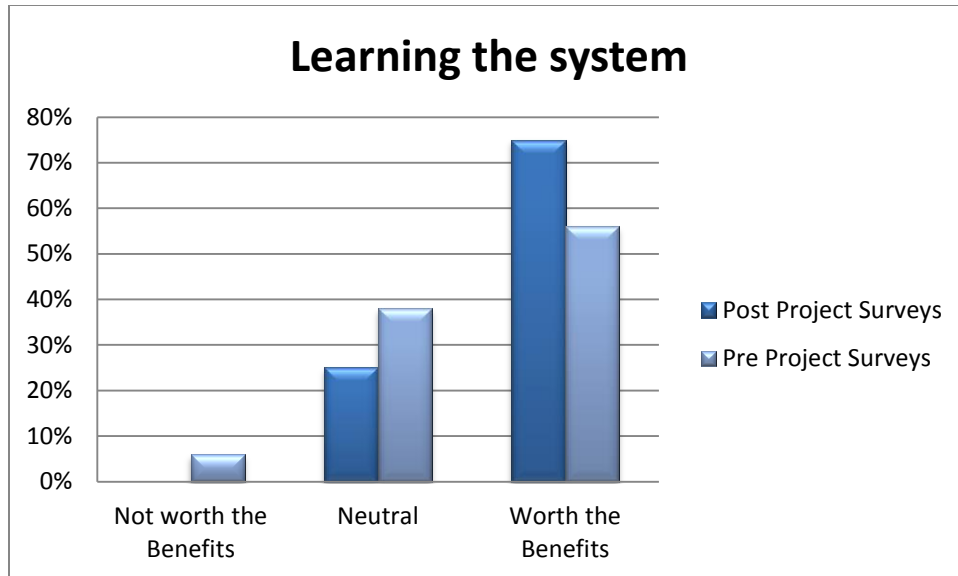
The surveys were sent to 35 project team members. Nine project members responded, representing a 25.7% response percentage. From those nine responses, one mentioned that his/her involvement with AEC-Sync (Attolist) was not significant. This member did not complete the survey questionnaire. The survey responses, then, includes eight respondents, which represents 22.9% of the initial population of people who were sent the surveys.

Among the survey respondents, 62.5% were Iowa DOT staff and employees, 25% were subcontractors or suppliers, and 12.5% were consultants to the project. There were no responses from the contracting agency (contractors).

#### *Survey Responses and Analysis*

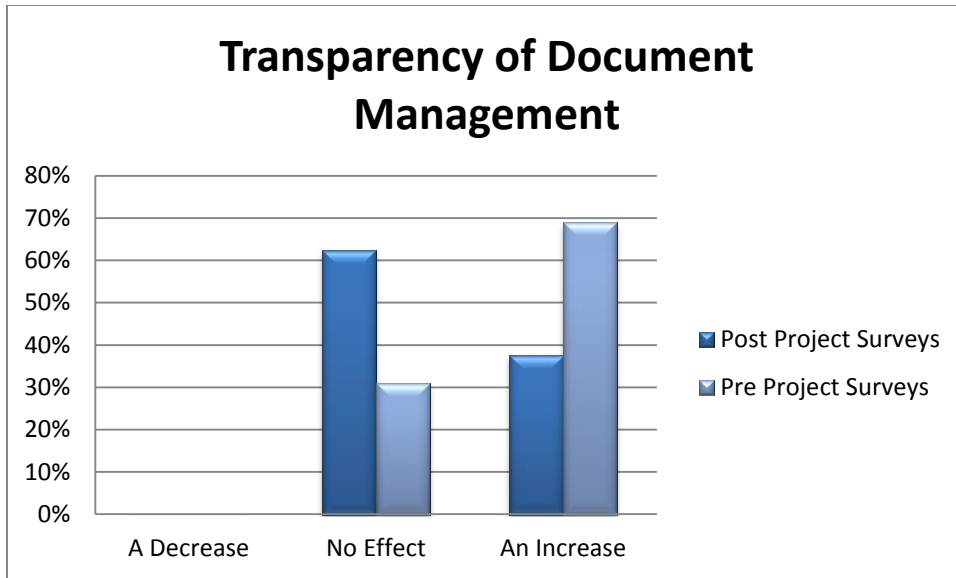
For the scope of this report, only several questions are shown in this section; the rest are found in Appendix A.

An interesting result that was found was that more respondents found it worthwhile to learn the WPMS compared to the pre-project survey results. The responses can be seen in Figure 1.

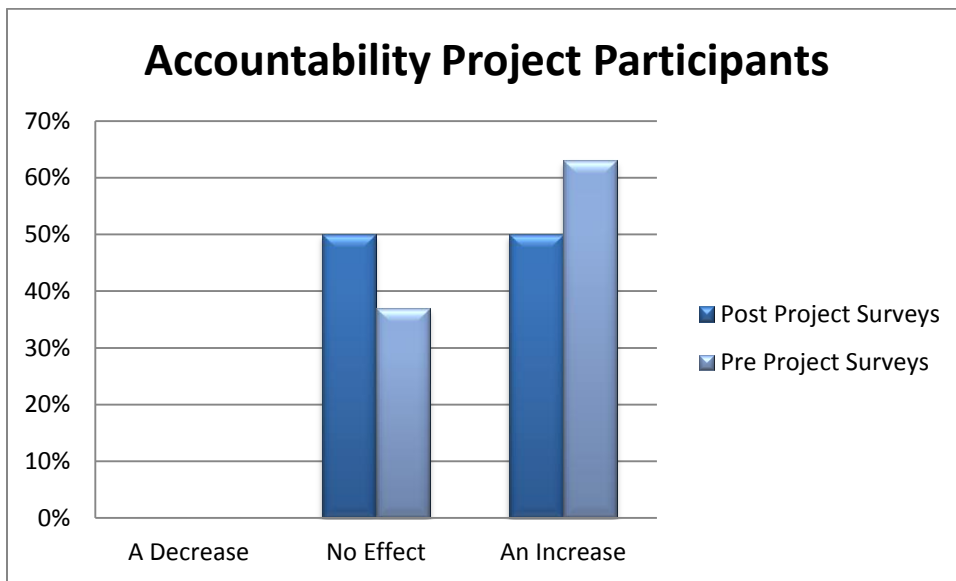


**Figure 1. Survey results – learning the system**

When respondents were asked about the effect of the WPMS on the transparency of document management, it was found that the respondents were expecting the WPMS, during the pre-project phase, to increase the transparency of document management. When respondents were asked the same question in the post-project surveys, the results showed that the respondents found no change in the transparency of document management. Even though the result was not the one that was expected, it is still a positive response related to the implementation of the WPMS. This indicates that the WPMS did not affect negatively document management within the Iowa DOT and that the current document management strategies within the Iowa DOT are transparent enough compared to what the WPMS can offer. Figure 2 shows the results concerning this topic. A similar result was seen concerning the topic of the accountability of the project member participants. During the pre-project survey stage, it was expected for the WPMS to increase the accountability of the project members by around 60%. After the post-project surveys were analyzed, it was found that half of the respondents believed that the WPMS positively affected the accountability of the project members, while the other half said that there was no effect. This can be seen in Figure 3.

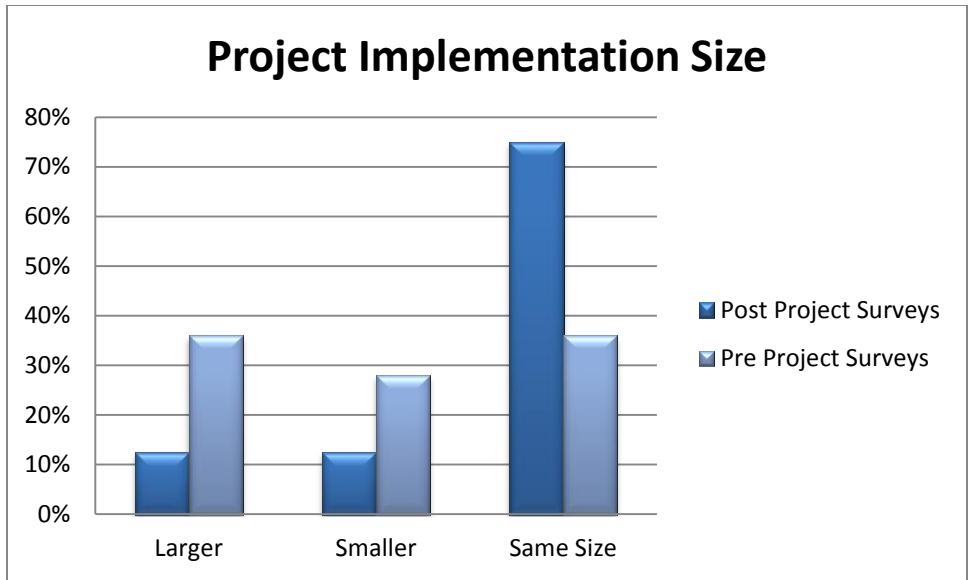


**Figure 2. Survey results – transparency of document management**



**Figure 3. Survey results – accountability of project participants**

When respondents were asked about the size of projects that they considered could benefit from a system like AEC-Sync, the answers from the pre-project surveys differed from the post-project survey results. During the pre-project phase, the answers were almost evenly spread between smaller, larger, or same-sized projects. During the post-project phase, around 75% of the respondents found that a WPMS like AEC-Sync could most benefit a project that is around the same size as the Iowa Falls Arch Bridge project. This answer indicates that maybe AEC-Sync is too simple for larger projects, but too complex for smaller projects. This result can be seen in Figure 4.



**Figure 4. Survey results – project implementation size**

In Appendix A, the rest of the responses are graphed and compared to the pre-project surveys. It should be noted that because the percentage of respondents was low in comparison to the population, only limited generalization can be drawn from the results.

## **WORKFLOW DEVELOPMENT**

Workflow documentation is one of the main objectives for this research project. It not only helped to identify an available commercial system that meets the Iowa DOT requirements, but also allowed the research team to select Microsoft SharePoint as the WPMS to implement for the smaller highway projects. These workflows can also be used as a guide for future SharePoint or WPMS implementation that the Iowa DOT might encounter.

Workflows are being used to manage complex processes that are internet- and virtual-based (Müller et al. 2004). Workflows are able to document, regulate, and separate business and office work activities into defined tasks, roles, rules, and procedures (Georgakopoulos et al. 1995). According to Casati et al. (1997), tasks are work units within the workflow model that are assigned to agents to perform; tasks are also referred to as the agent's role within the workflow process model. Workflows can be used to re-engineer information and automated business processes within an organization (Georgakopoulos et al. 1995). Three types of workflows available are as follows:

- Material process workflows: Model the assembly and delivery of physical products.
- Information process workflows: Model automated tasks that are involved in the creation, process, and management of information. This usually involves systems that provide basic technological infrastructure that support information processes.
- Business process workflows: Model market-centered processes within an organization (Georgakopoulos et al. 1995)

### **Methodology**

One of the important aspects of documenting Iowa DOT workflows for future WPMS implementation is to identify different work components or projects that could benefit from a WPMS implementation. After a discussion with the TAC, the decision was made to document the workflow for all the shop drawings or working drawings that are documented in Section 1105 of the Iowa DOT Specifications, "Control of Work". Table 1, based on Table 1105.03-1: Review Offices for Working Drawings (Iowa DOT 2011), lists the different shop/working drawings with the respective main review office.

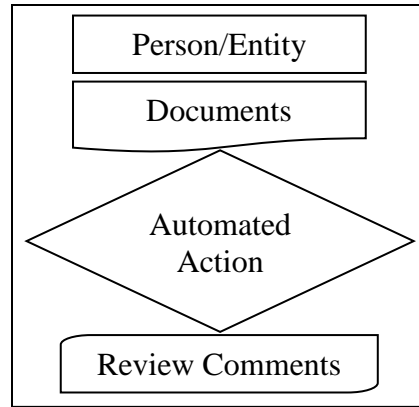
After the various shop/working drawings that could benefit from a WPMS implementation were identified, interviews were held with the various review offices. These interviews helped the research team identify the required tasks and the relationships involved in the approval process for these drawings. An important aspect of these interviews was that they were held independently and individually per office. This gave the research team the opportunity to understand and better capture the approval process for each of the respective offices and offer a workflow that best suited their respective needs. After conducting these initial meetings, the research team developed the workflows based on the requirements identified during the interviews and the specifications for each of the corresponding shop/working drawings. Follow-

up meetings were also scheduled in order to review the documented workflows for accuracy with the respective offices.

All the workflows were created in word processing software, such as Microsoft Word, using the drawing tools option. Arrows were used to connect the various tasks and symbols, shown in Figure 5, and to represent various tasks, actions, and processes within the workflow.

**Table 1. Shop/working drawings for Iowa DOT (Iowa DOT 2011)**

Description	Review Office
Falsework for slab bridges	Bridges and Structures
Cofferdam design	
Reconstruction of substructure	
Steel Structures	
Detail plans for falsework or centering support of steel structures	
Steel and aluminum pedestrian hand rails	
Precast concrete	
Tower lighting	
Bridge components	
Pre-engineered steel truss recreational trail bridge	
Removal of box girder bridges	
Structural erection manual	
Temporary shoring	
Temporary sheet pile retaining wall	
Safety grates for RCB culverts	
Highway lighting	Traffic and Safety
Highway signing steel breakaway posts	
Traffic signalization	
Highway signing – Type A and B signs	Soils Design Section
MSE, segmental, and modular block retaining walls	
Soil nail and tie-back retaining walls	
Intermediate foundation improvement (IFI)	



**Figure 5. Legend of symbols**

## Results

After the researchers met with the various offices within the Iowa DOT responsible for each corresponding shop drawing review, the workflows were established and documented. These workflows can be used to identify and evaluate WPMS that could ease the document management and shop/working drawing review process. Later, after identifying a WPMS that can be implemented, these workflows can be used as the model to develop the various processes and pages for the selected WPMS.

An interesting observation found during the workflow interviews was that, even though there are multiple working drawing processes, many of these share the same tasks, relationships, and processes. These can clearly be seen with the shop drawings that have to be reviewed by the Bridges and Structures office. There are 15 shop drawing review processes for which this office is responsible, but these can be categorized into five different workflow models.

The first of these workflow models covers working drawings for various procedures for bridge construction and demolition, including falsework for slab bridges, detail plans for falsework, or centering support of steel structures, structural erection manuals, and precast concrete, removal of box girder bridges, and pre-engineered steel truss recreational trail bridges. Figure 6 illustrates the structural erection manual workflow.

The second workflow model corresponds to the handrails and steel structures and the bridge components workflows. This workflow model is somewhat similar to the first model, but it incorporates an additional office, Central Materials, that reviews the drawings. This model is represented in Figure 7.

The third model also is derived from or is similar to the first workflow model. The most noticeable difference is that it includes an alternate process that is used if the drawing has to be reviewed by the Office of Soils Design. If the drawing has to be reviewed by the Office of Soils Design, it has to be reviewed by this office before Bridges and Structures, the responsible office for the shop drawing, can begin the document's review process. This process is identified in the

workflow with dashed lines. There are two shop drawing processes that share this model: cofferdam design and reconstruction of substructure. This third model can be seen in Figure 8.

The fourth model involves two additional offices, aside from the Office of Bridges and Structures, to revise the shop/working drawings. This model corresponds to drawings that also involve the review of the Central Office of Materials and the Office of Traffic and Safety. The components that need to be reviewed are sent for review to the pertinent office. For example, the weld procedures are sent to the Central Office of Materials for review. Figure 9 presents the workflow for the following types of projects: safety grates, highway sign support structures, and tower lighting.

The fifth and last model corresponds to the sheet pile retaining walls and temporary shoring systems workflows. These are different from the previous workflows because they first have to be reviewed by the Office of Soils Design before being reviewed by the Office of Bridges and Structures. The workflow model is depicted in Figure 10.

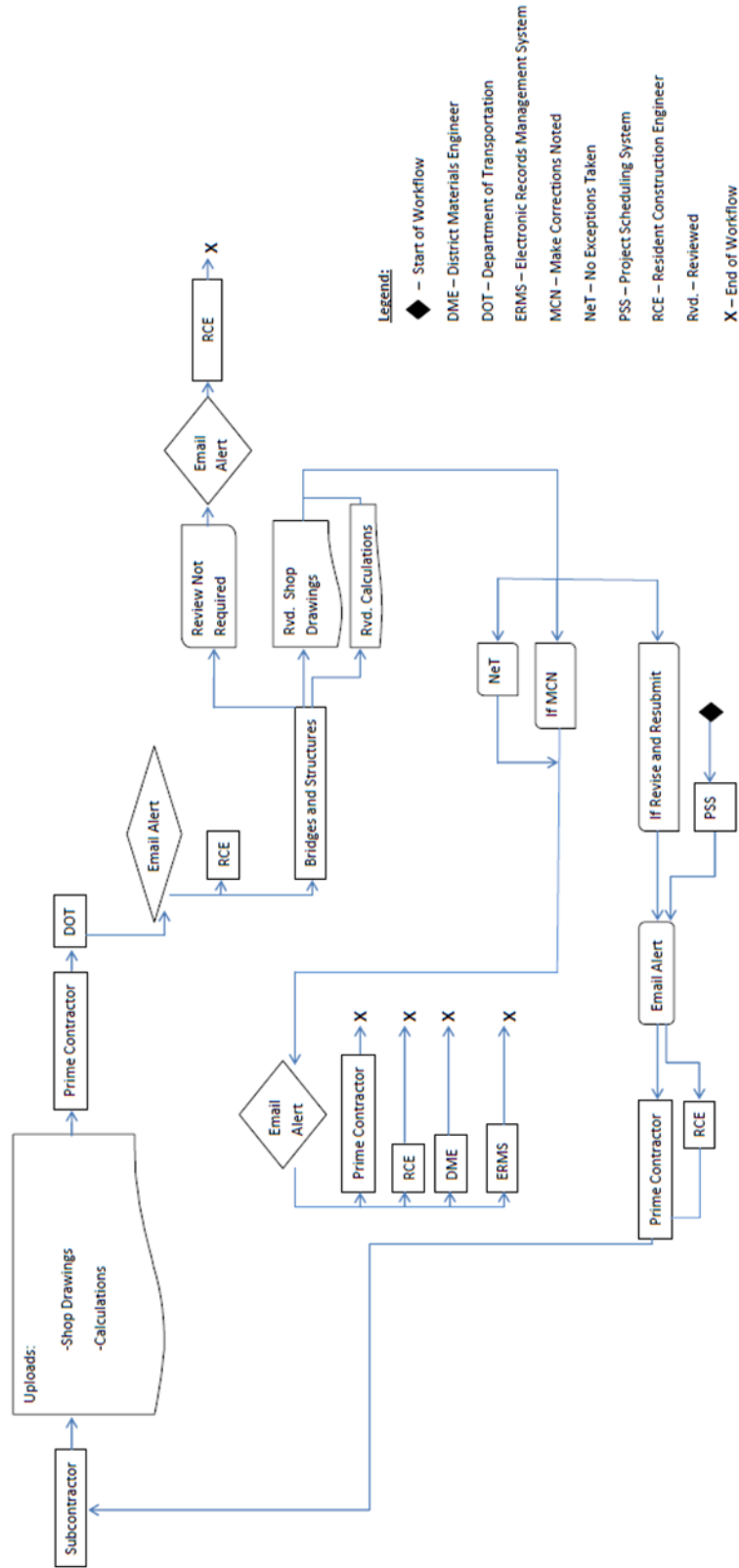
The same observation was found in the other shop/working drawings to be reviewed by the other offices of the Iowa DOT. In the case of the Office of Soils Design, the three working drawings workflows were represented in two models. For the working drawings under the responsibility of the Office of Traffic and Safety, there were four workflows, represented in two models. For brevity, these models are not shown in the body of this report. However, the workflows for submittals investigated for this project are displayed in Appendix B.

### **Request for Information Workflow**

A request was made by Iowa DOT to also develop workflows for requests for information (RFI). This request was addressed by a separate author, Francis O. Dayamba, and the requested workflow is documented in Appendix C.

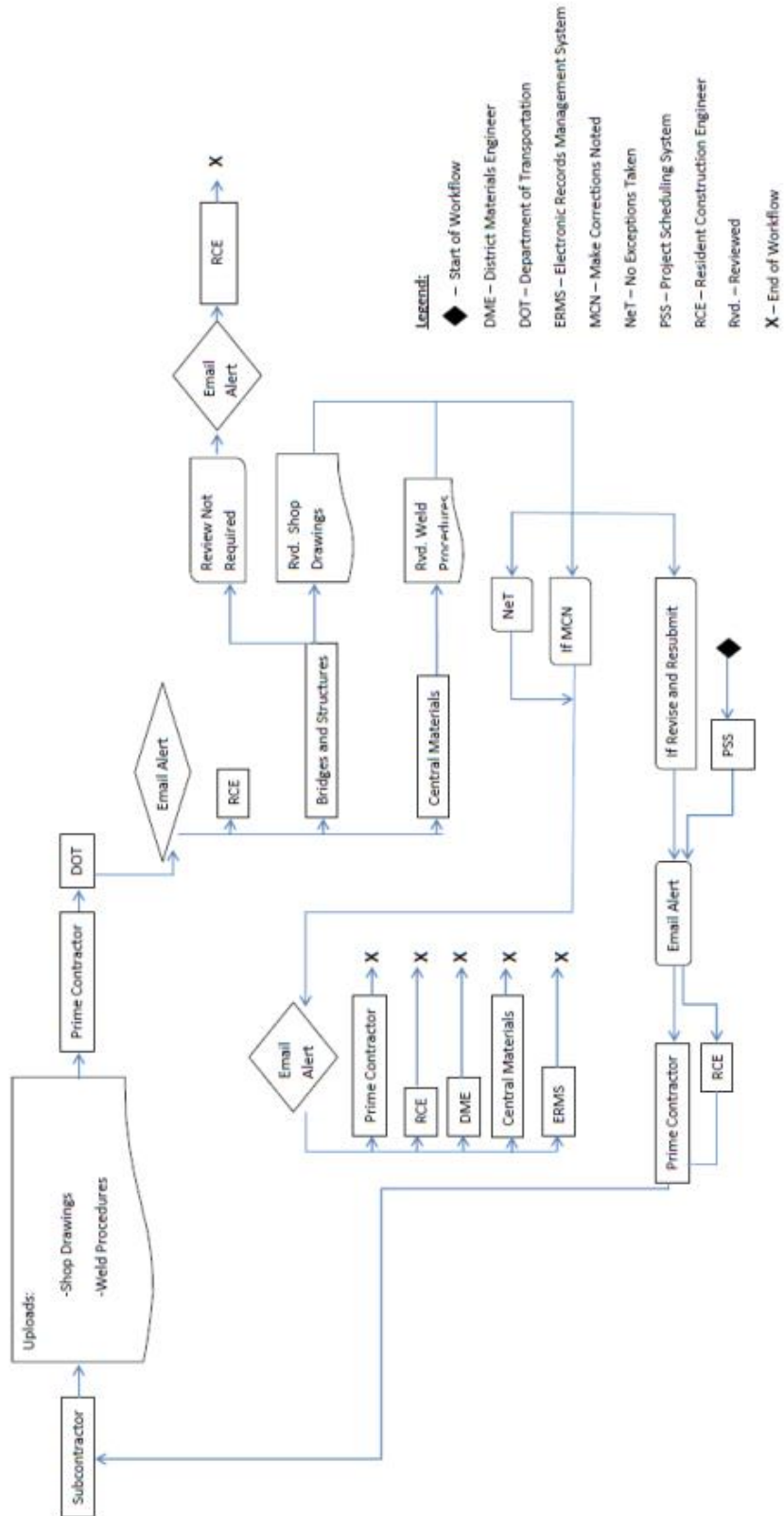


## Workflow: Structural Erection Manual



**Figure 6. Structural erection manual workflow**

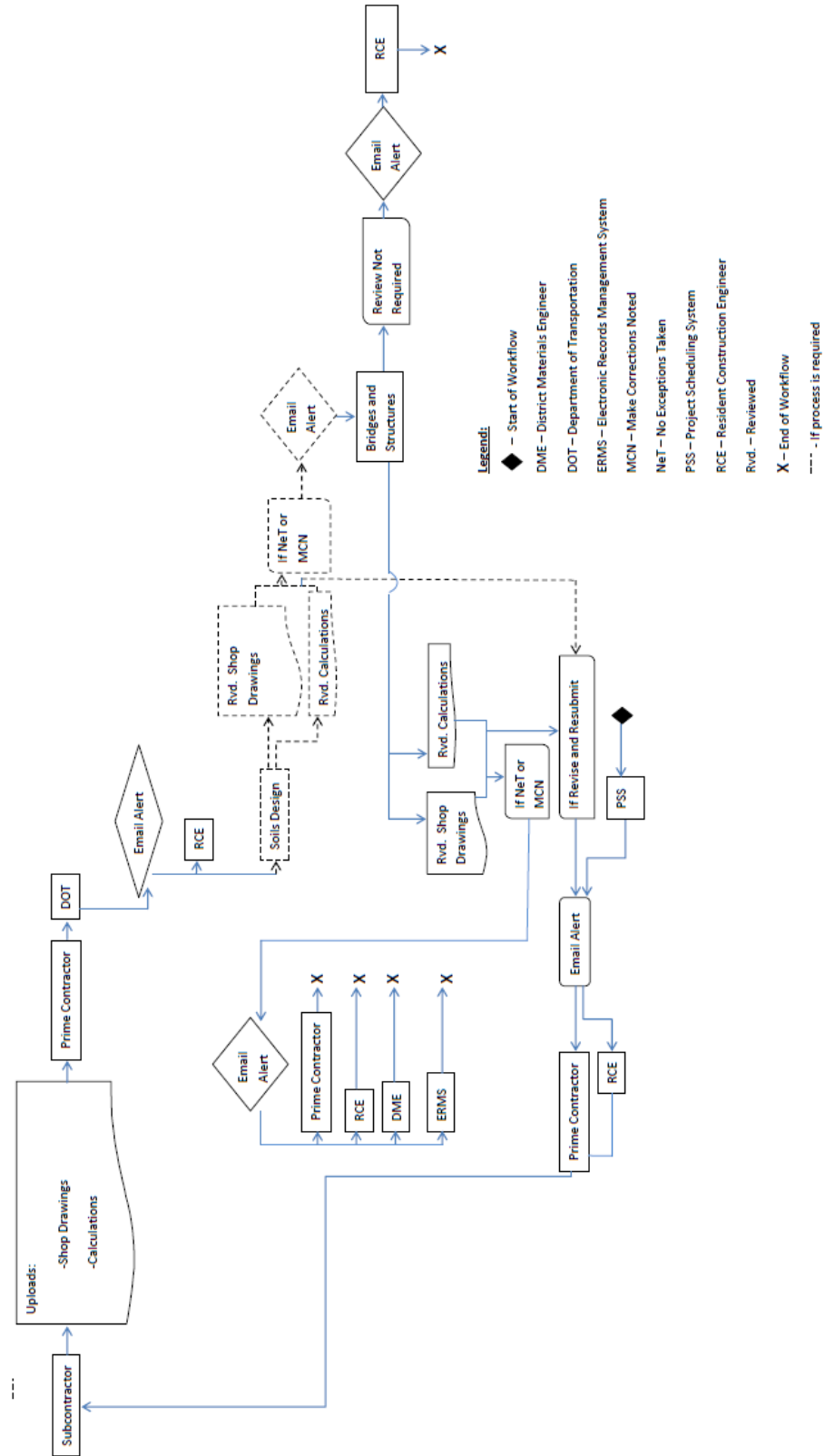
### Workflow: Steel and Aluminum Pedestrian Handrails



- Legend:**
- ◆ – Start of Workflow
  - DME – District Materials Engineer
  - DOT – Department of Transportation
  - ERMS – Electronic Records Management System
  - MCN – Make Corrections Noted
  - NeT – No Exceptions Taken
  - PSS – Project Scheduling System
  - RCE – Resident Construction Engineer
  - Rvd. – Reviewed
  - X – End of Workflow

Figure 7. Workflow for the steel and aluminum pedestrian handrails

## Workflow: Cofferdam Design



**Figure 8. Cofferdam design workflow**

### Workflow: Safety Grates

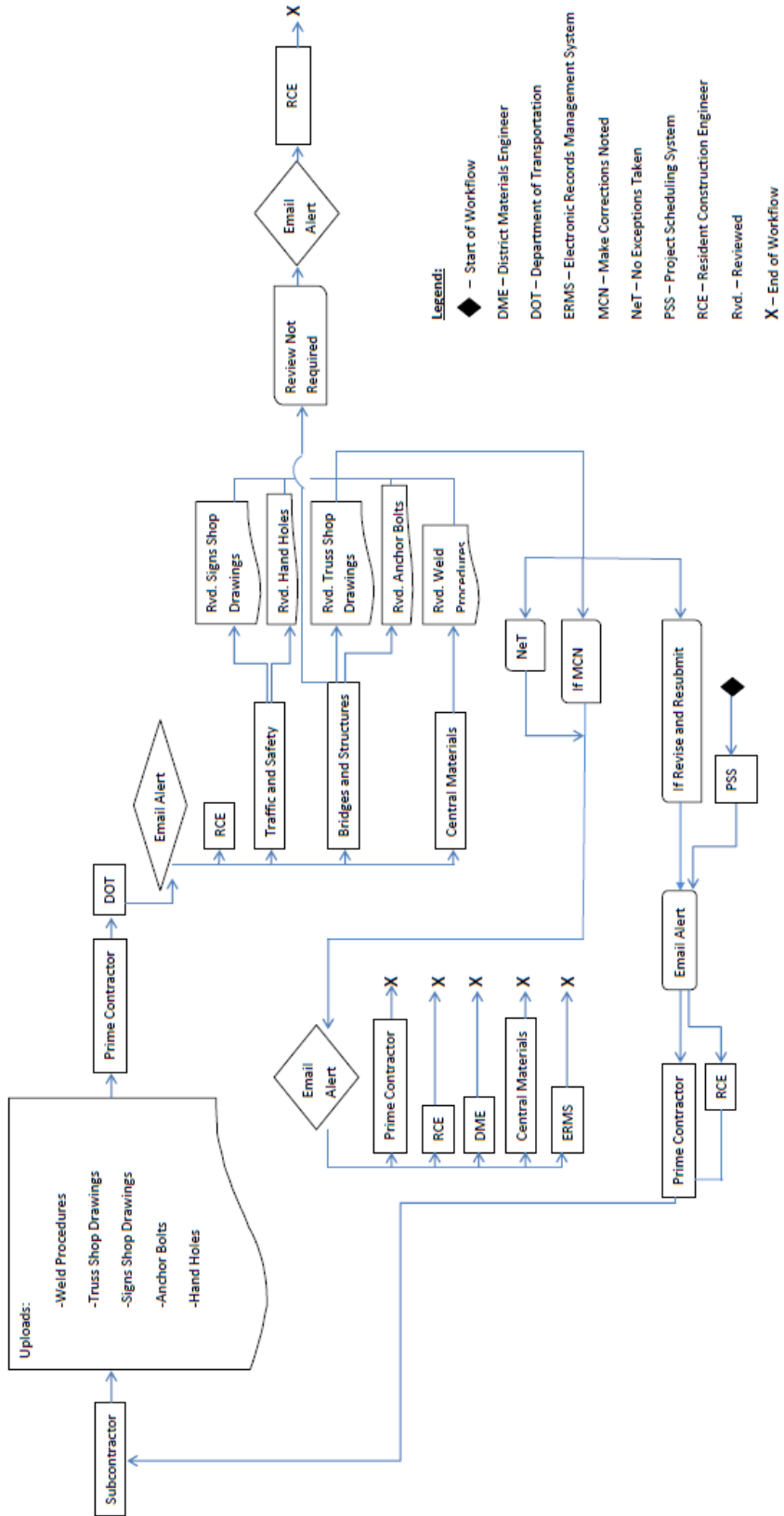
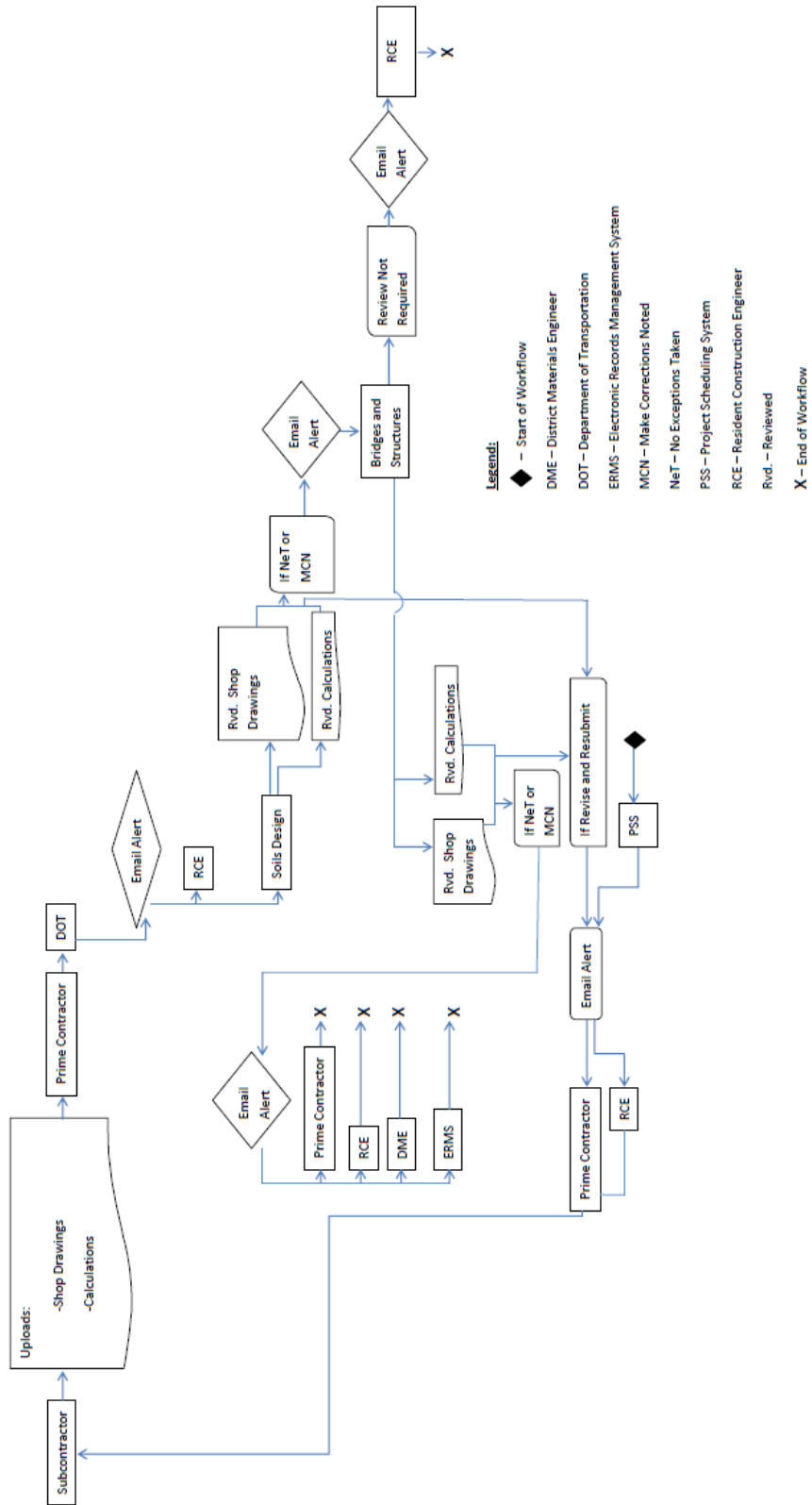


Figure 9. Safety grates workflow

## Workflow: Temporary Sheet Pile Retaining Walls



**Figure 10. Temporary sheet pile retaining walls workflow**

## **Analysis**

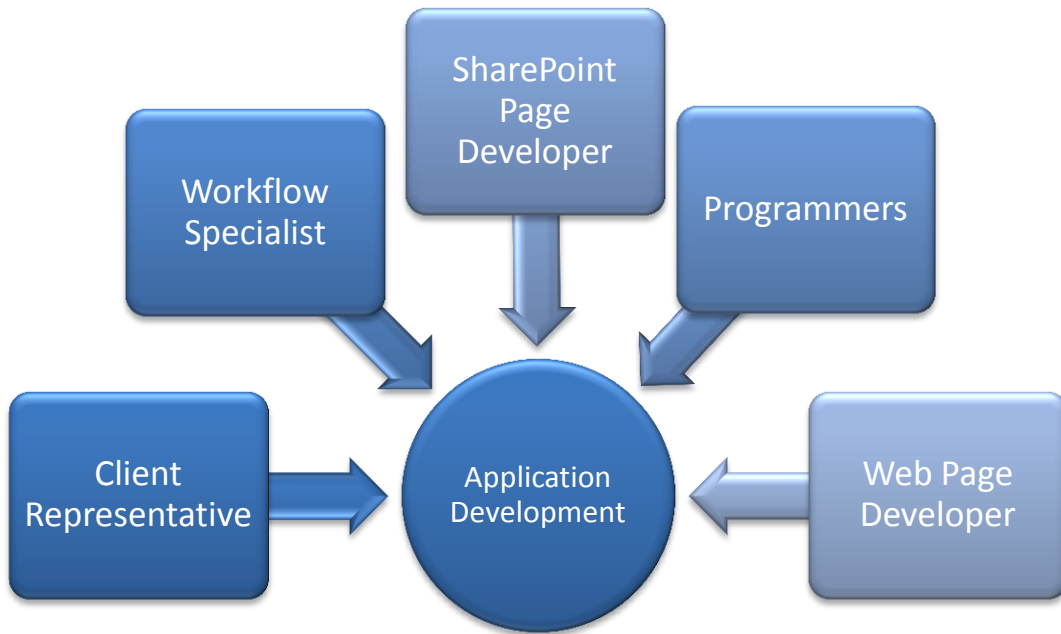
As noted in the results section, various work processes for the respective shop drawing approval processes were able to be grouped together. At the beginning of the project, this was unexpected, but during the interviews it was found that a number of working drawings shared the same evaluation process and workflow. This highlighted the importance of documenting and developing workflows for these processes. It gave the reviewing offices at the Iowa DOT and the research team the opportunity to graphically visualize the review processes of these shop/working drawings and realize that most of their review processes share tasks and relationships. It also gave the review offices the opportunity to identify whether there was a need for re-engineering certain components of these processes. Documenting the workflows helped the research team understand the requirements that the Iowa DOT needed in a WPMS. The workflows developed served as a model to identify and evaluate possible WPMS solutions. For the TAC, the workflows represented a guide to develop pages and solutions within the WPMS.

## **SHAREPOINT IMPLEMENTATION**

As stated previously, Microsoft SharePoint was the software tool that was selected for implementing electronic collaboration for smaller highway projects. SharePoint is a document management system that can be integrated and allowed to communicate with other software applications, such as email and personal content management systems (such as Microsoft Outlook); previously existing programs; and users. At the time SharePoint was selected, the State of Iowa was considering the use of SharePoint for several applications, and the selection of SharePoint for this project was intended to provide synergy with other applications. Since the selection was made, the State of Iowa is re-evaluating SharePoint and may choose a different software tool that has a similar function. Although the platform may change, the workflows and basic concepts will remain as described herein.

The Microsoft SharePoint pages are developed in-house by specialist information technology personnel, herein referred to as SharePoint Page developers, using SharePoint's established rules and settings. The server space and the storage capacity depend on the in-house server capacity. There are two types of licenses available when purchasing SharePoint: the internal and external licenses. With the internal license, only the people within the internal network (in this case, usually employees of the contracting authority) can access the SharePoint page and contribute to the document exchange process. With the external license, people outside of the network (such as, in this case, contractors, subcontractors, suppliers, and consultants) can access the documents for which the SharePoint page developer has given permission.

An important requirement for successfully developing and implementing a WCMS, such as Microsoft SharePoint, in construction projects is to form a team that can understand the requirements needed for the site implementation. This team can be created by the client requiring the development of the SharePoint page. The client or the client's representative determines and selects the team members involved in the SharePoint page development based on their experience and qualifications. Figure 11 depicts the various team members involved in the development of SharePoint for the Iowa DOT.



**Figure 11. The SharePoint development team**

The responsibility of the workflow specialist is to document the workflows of work processes that are going to be automated in Microsoft SharePoint. To document the workflows, interviews with relevant personnel have to be scheduled so that the various tasks and their relationships within the work process can be identified. These workflows need to correctly depict the work processes because they will serve as the backbone for the SharePoint page development.

The SharePoint page developer is involved in the development of the various work processes managed by the SharePoint page. The developer uses the workflows developed by the workflow specialist to create the document libraries within SharePoint and set the restrictions to these. The restrictions set the required rules and specifications for the established workflows. The SharePoint page developer may need to communicate with computer programmers to devise a way to initiate the SharePoint page at the beginning of the project in such a way that it is preloaded with important project information, known as metadata.

The programmer's responsibility is to help identify a way that the SharePoint page can be initiated automatically at the beginning of the work process. The programmer is also responsible for integrating the SharePoint page into any electronic systems or server spaces that the client may have already established.

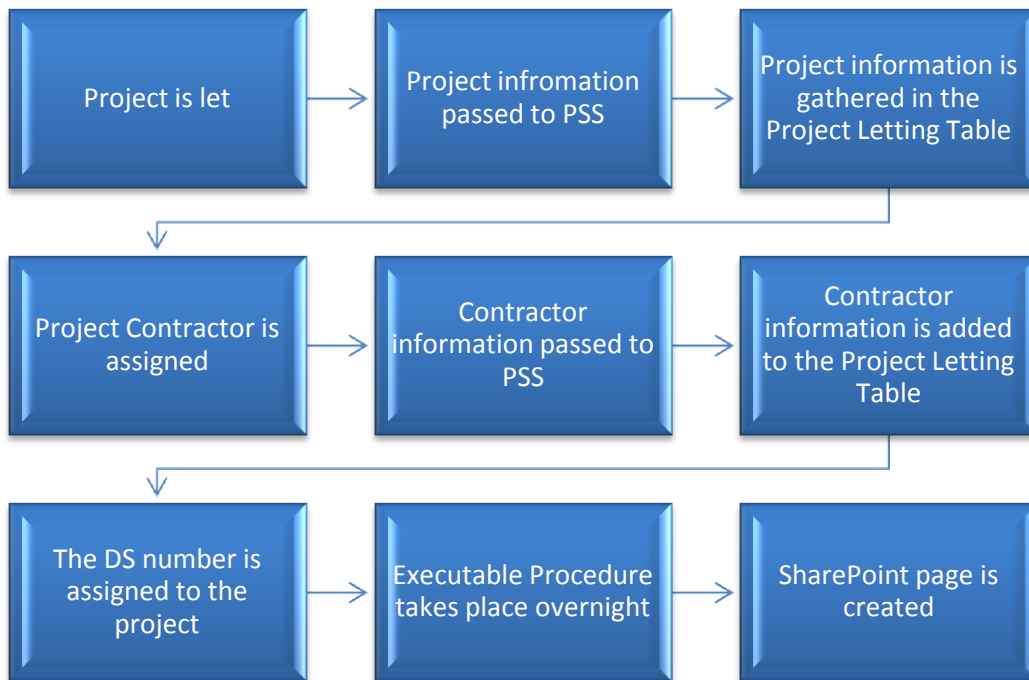
The web page developer is responsible for developing the portal. The portal is the web page on which a user initially lands when accessing SharePoint, which includes branding for the contracting authority and important partners, authentication for application users, and other miscellaneous notices and web links that may be helpful to users.



## Microsoft SharePoint and Project Initiation

One of the goals for the SharePoint system was to initialize a page automatically after a contract for a project has been signed. After discussing this with the TAC, it was chosen to have this process automated based on the project's metadata, types of shop drawing submittals required, and project letting date.

The Iowa DOT uses an executable procedure that runs every night to identify projects that are newly under contract or that have new project information that has been entered into the Iowa DOT Projects Letting Table. The procedure is able to redistribute the information to other internal databases or servers and to initiate other programs associated with the project. This executable procedure was chosen to initiate the project's SharePoint page. A developmental specification (DS) number, a number recorded with a specific project and metadata, is added to the Projects Letting Table by the Project Scheduling System (PSS) office after the project is let and the contract is executed. After this DS number is entered into the Projects Letting Table, the executable procedure runs, triggering the creation of a general SharePoint page. The workflow that summarizes this process is shown in Figure 12.

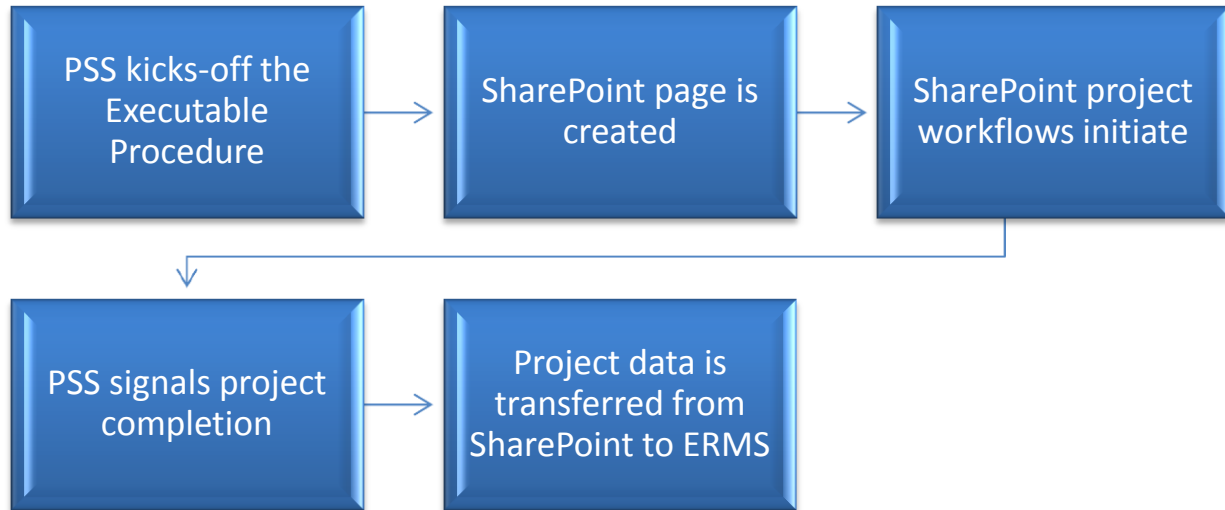


**Figure 12. SharePoint page initiation workflow**

## Microsoft SharePoint throughout the Project's Duration

After the SharePoint page is created, additional project metadata are entered into the SharePoint page. This allows for all the different workflows involved in the project to execute properly. The workflow in Figure 13 summarizes the process to be executed after the SharePoint page is

developed. The workflow depicts a process that is still in the development stage and that has not been tested. After implementation, the process will be evaluated to identify any possible opportunities for improvement. A note about this workflow is that the metadata provided by PSS at the initiation of the project SharePoint page will be updated as the project continues until its completion.



**Figure 13. SharePoint project cycle**

The activity in Figure 13 corresponding to the initiation of the SharePoint workflows includes several processes. The first process that SharePoint will go through is to identify that the SharePoint site has been created. It is through this process that various “SharePoint Member Groups” will be created using the information provided by PSS. “SharePoint Member Groups” is a SharePoint feature that allows project members and participants that share the same responsibilities within the SharePoint site to be grouped together so they receive the same notifications. The act of creating these groups will grant access permission to the various parties involved in the project and the shop/working drawing submittal and review process. The various groups created will also allow for the automatic SharePoint notifications to take place. The second and third processes involved in the SharePoint workflows activity are the shop drawing review workflow, which was documented earlier in this paper, and the workflow for the outcomes of the review. The review workflow will distribute the uploaded document to the corresponding Iowa DOT office so the review can take place. The outcomes workflow will be based on the result of the review process, and the reviewer will categorize the document based on the result of the review. If a resubmission is required, the contractor will be notified, and the review and outcomes workflows will be launched again. If a resubmission is not required, the outcomes workflow will end.

The last two activities in Figure 13 go hand in hand. When PSS signals the process for the completion of the project, the Iowa DOT will save a record of the documents involved in the projects in an archival system named the Electronic Record Management System (ERMS). The project’s metadata will also be sent to ERMS if queried by PSS. Recall that the initial project metadata can be transferred from PSS to SharePoint. At the end of the project, the metadata can

be transferred to ERMS from SharePoint and directly from PSS. At the writing of this report, the Iowa DOT Information Technology team is still identifying a way for the document transmittal from SharePoint to ERMS to take place.

## LESSONS LEARNED AND CONCLUSIONS

- The post-project surveys from the AEC-Sync Iowa Arch Bridge project implementation turned out to be positive. This result suggests that other Iowa DOT projects can benefit from a similar WPMS implementation.
- Documenting workflows for the review process before identifying a WPMS solution allowed the research team to understand the stakeholders' needs and compile all the requirements and specifications. This helped the research team identify a solution most suited for the Iowa DOT's needs.
- Documenting workflows allowed the implementation team to set the requirements and features for SharePoint, the selected WPMS solution for smaller projects. Documenting the workflows allowed the development and implementation team to understand the uses and features that SharePoint needed to provide to the end user in order to handle the document management involved in the shop/working drawings approval process.
- Even though the SharePoint pages for the Iowa DOT's smaller projects were not tested by actual users at the time this report was written, the workflows documented during this research were used to evaluate which software solutions would be capable of successfully implementing the WPMS application. If the SharePoint pages are able to perform all the tasks based on the established relationships, it appears that the likelihood of successful implementation could be high. If SharePoint pages do not appear to meet the requirements established in the original workflows, the SharePoint page implementation does not have to be classified as completely unsuccessful. The documented workflow allows either the re-engineering and possible modification of the SharePoint pages to better meet the users' needs and requirements or for the users to reconsider their needs.
- For successful WPMS development and implementation, a capable and integrated team has to be created. The project team should integrate various specializations. In the case of this research project, a team was formed that included information technologists, engineers, and academic researchers.
- SharePoint can be integrated with other programs, including executable processes that are developed in-house. This can be a way of automating the creation and initiation of SharePoint pages. This was not tested by actual users as of this writing; however, the TAC and researchers were able to develop and execute test programs to show that executable code developed in-house could be used to trigger the initiation of SharePoint pages.

## APPENDIX A. IOWA FALLS ARCH BRIDGE PROJECT SURVEY RESULTS

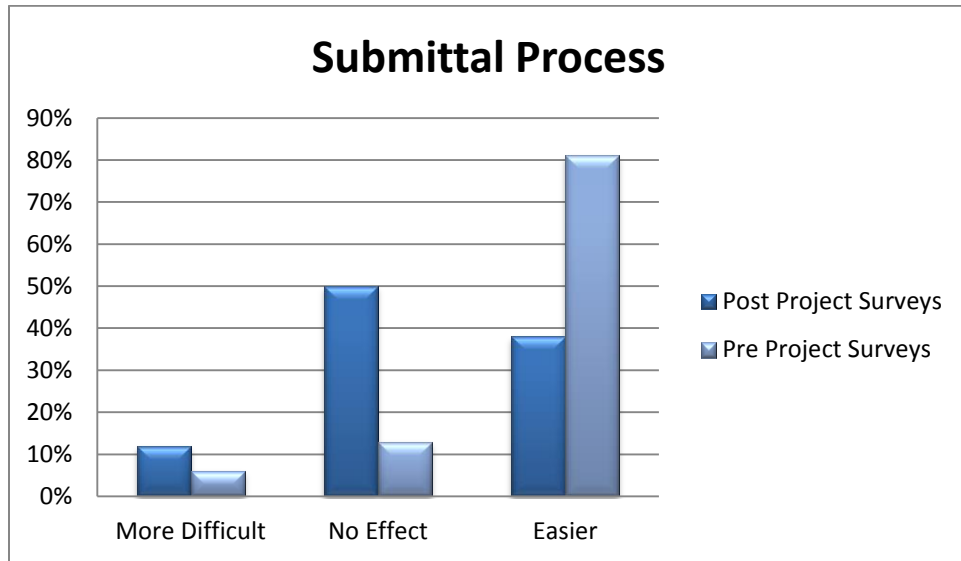


Figure A.1 Submittal process

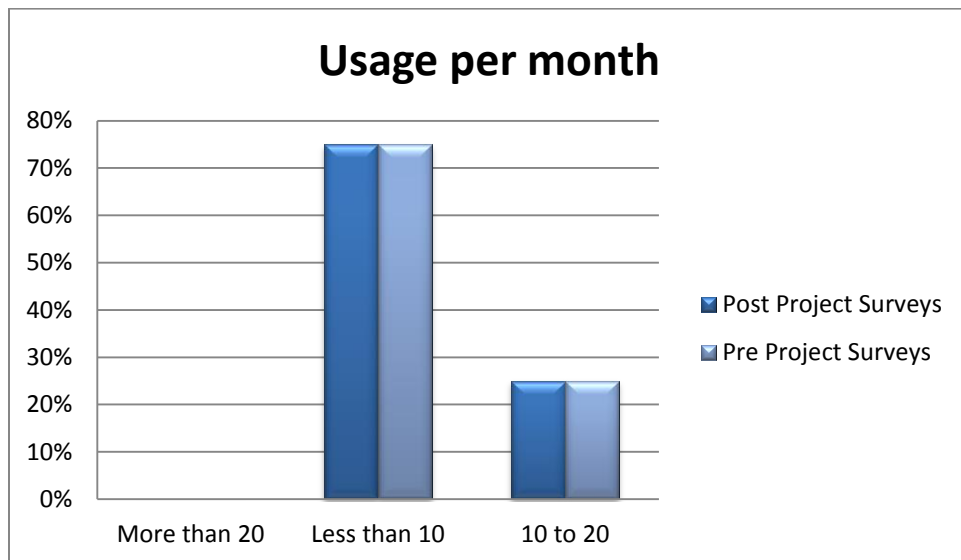
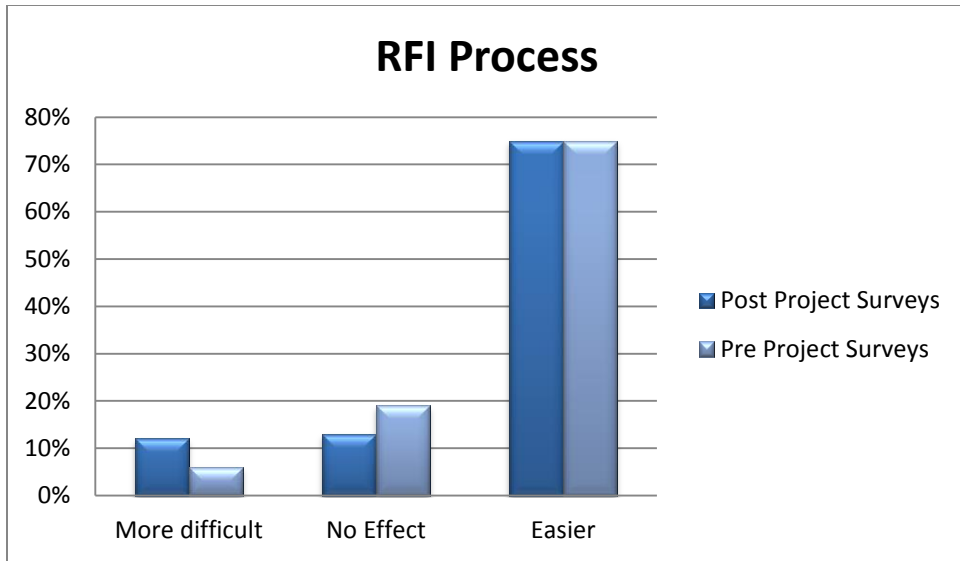
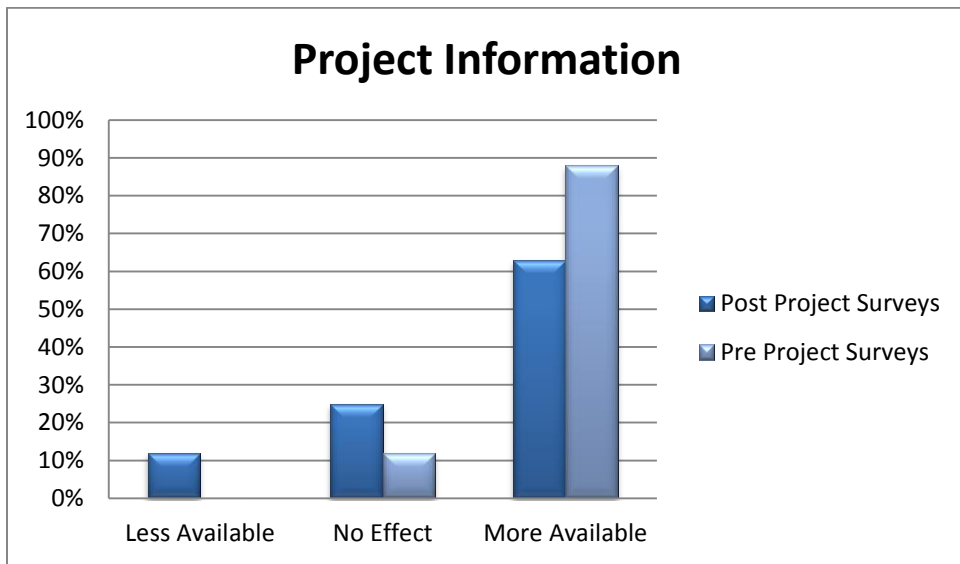


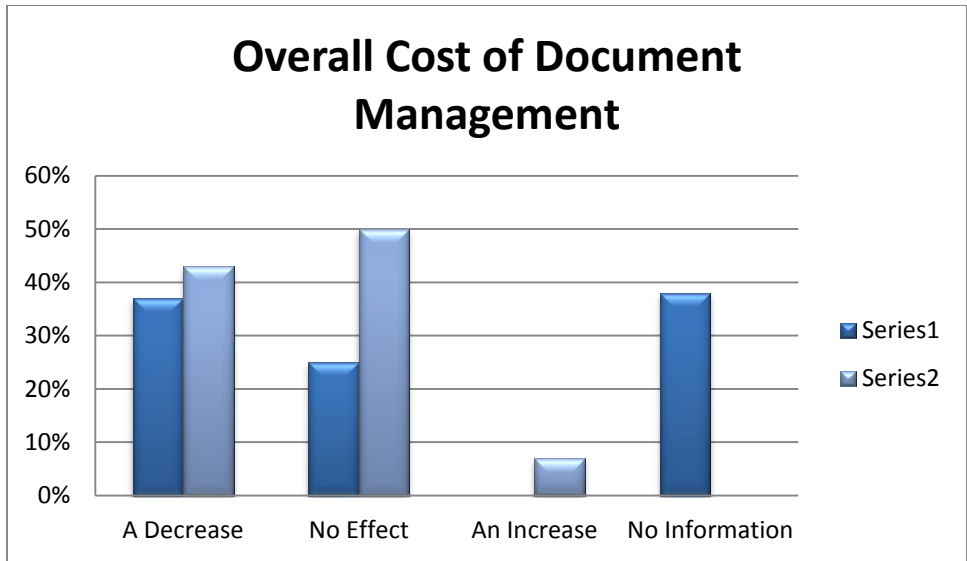
Figure A.2. Usage per month



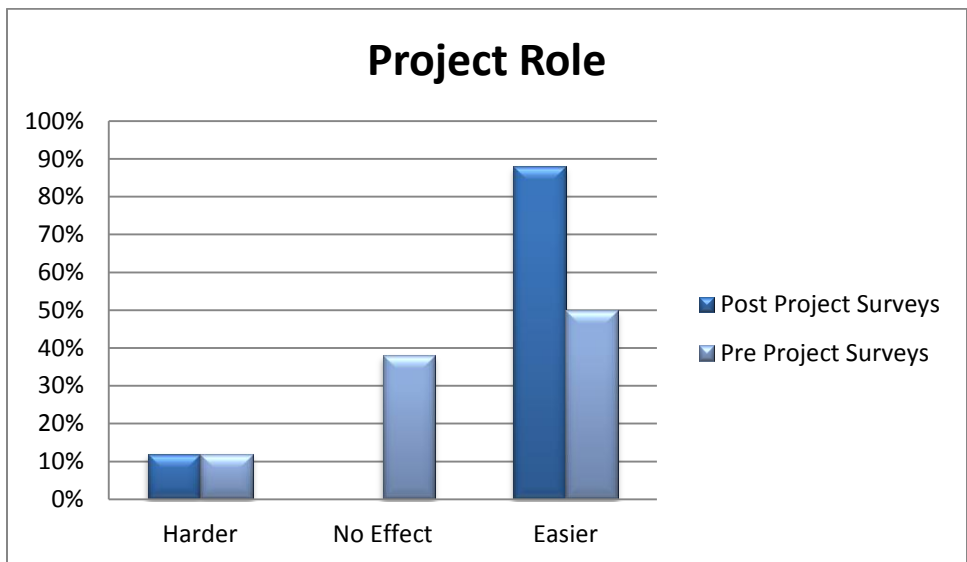
**Figure A.3. RFI process**



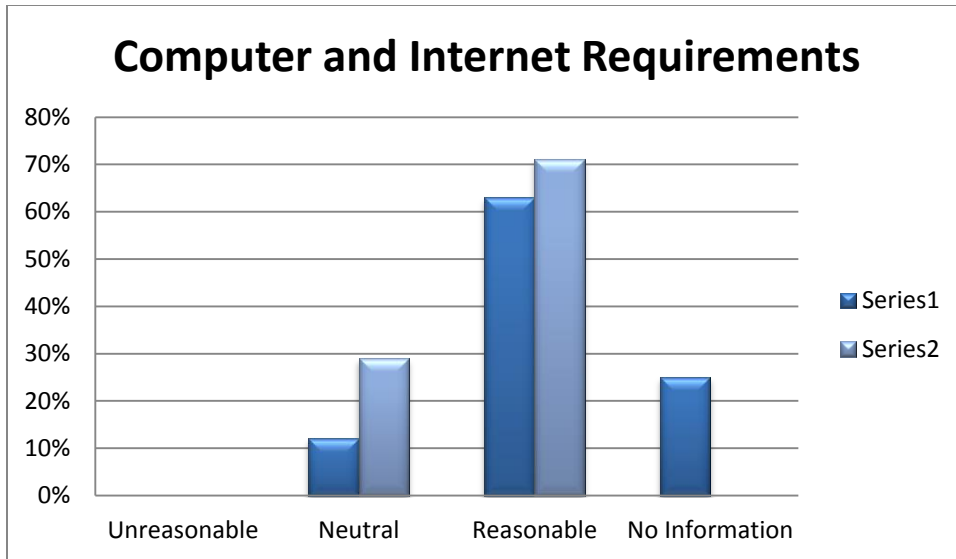
**Figure A.4. Project Information**



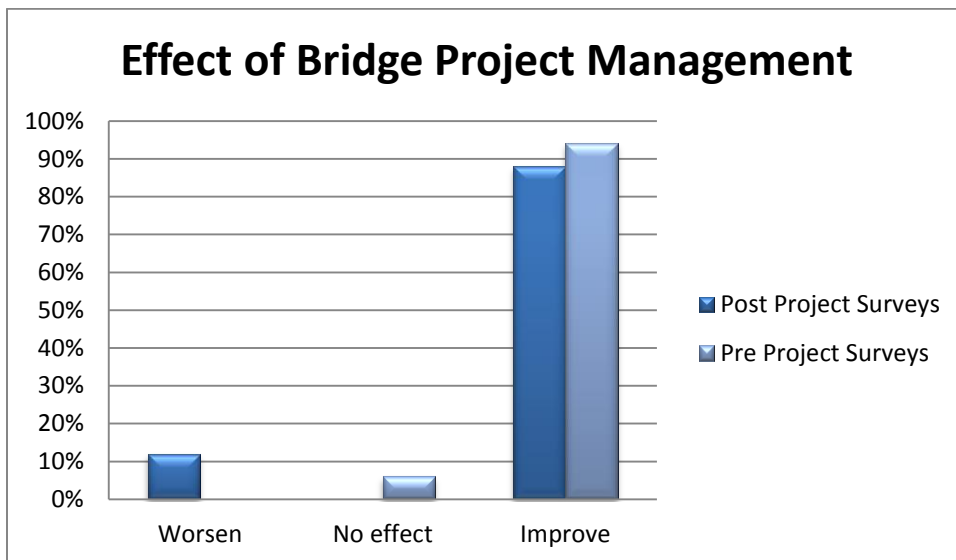
**Figure A.5. Overall cost of document management**



**Figure A.6. Project role**



**Figure A.7. Computer and internet requirements**

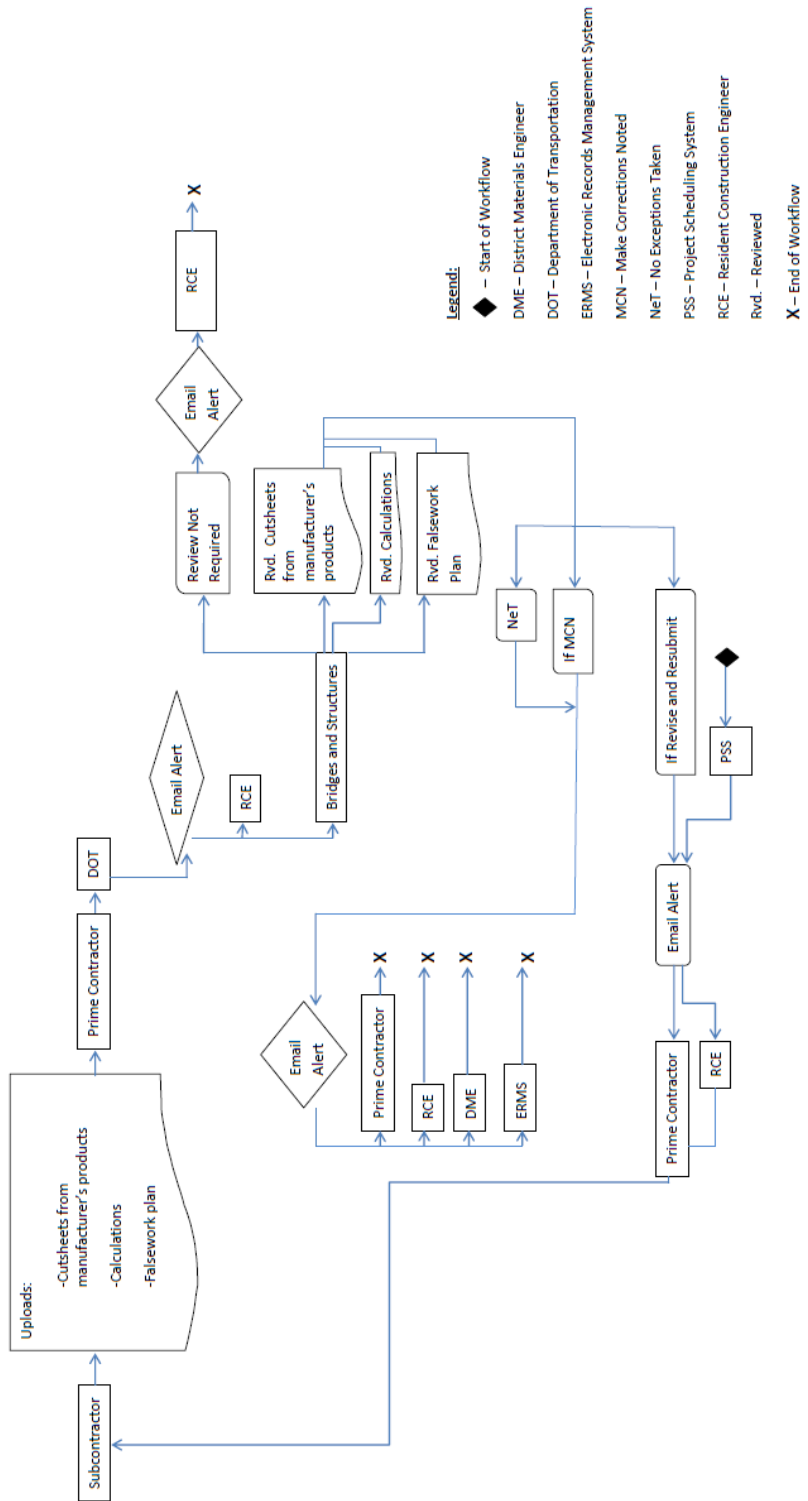


**Figure A.8. Bridge project management**



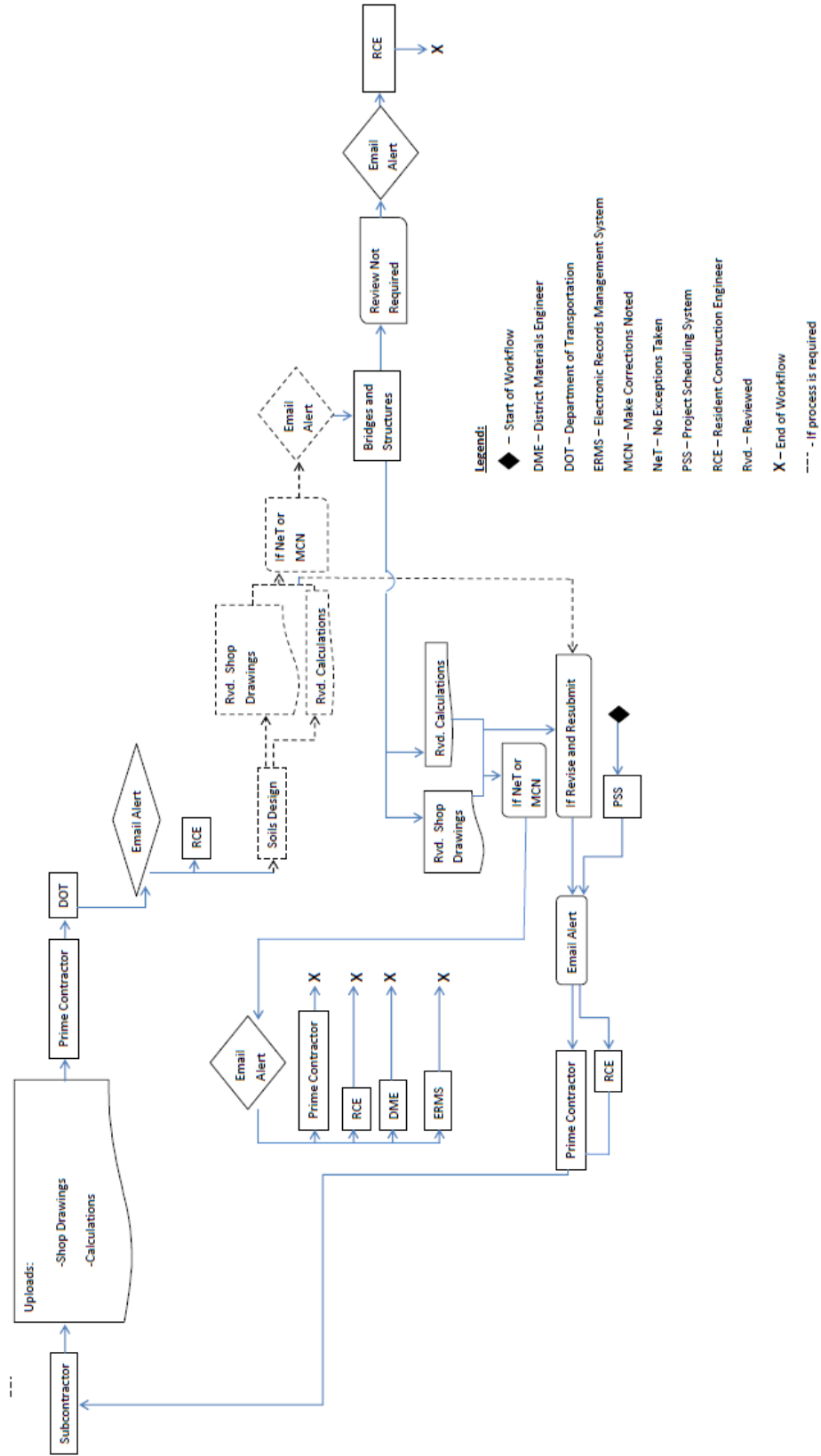
**APPENDIX B. SHOP/WORKING DRAWINGS WORKFLOWS FOR ACTIVITIES IN IOWA DOT SPECIFICATION SECTION 1105**

**Workflow: Falsework for Slab Bridges**



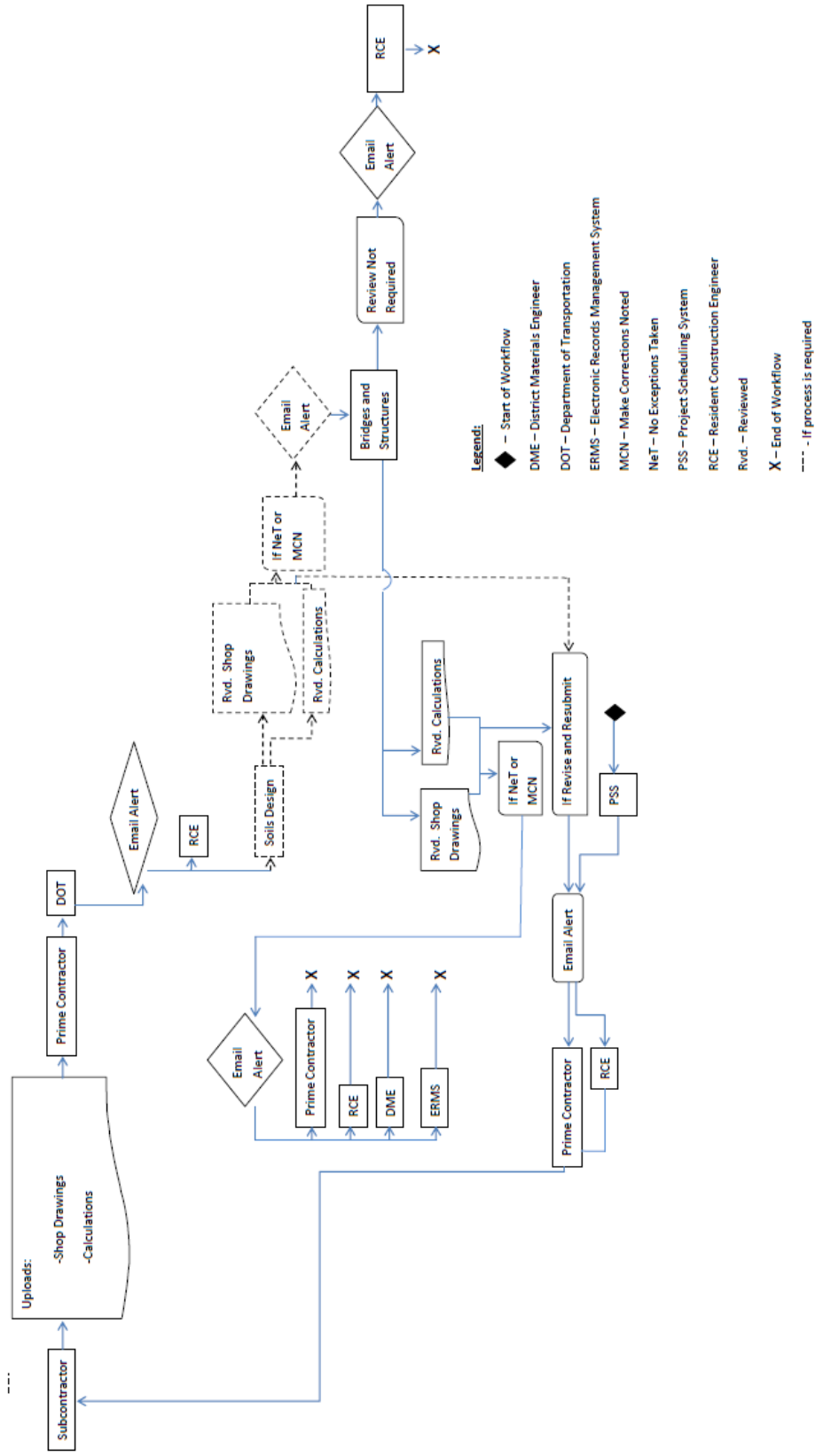
**Figure B.1. Falsework for slab bridges workflow**

## Workflow: Cofferdam Design



**Figure B.2. Cofferdam design workflow**

**Workflow: Reconstruction of Substructure (detailed plans for supporting the superstructure)**



**Figure B.3. Reconstruction of substructure workflow**

## Workflow: Steel Structures

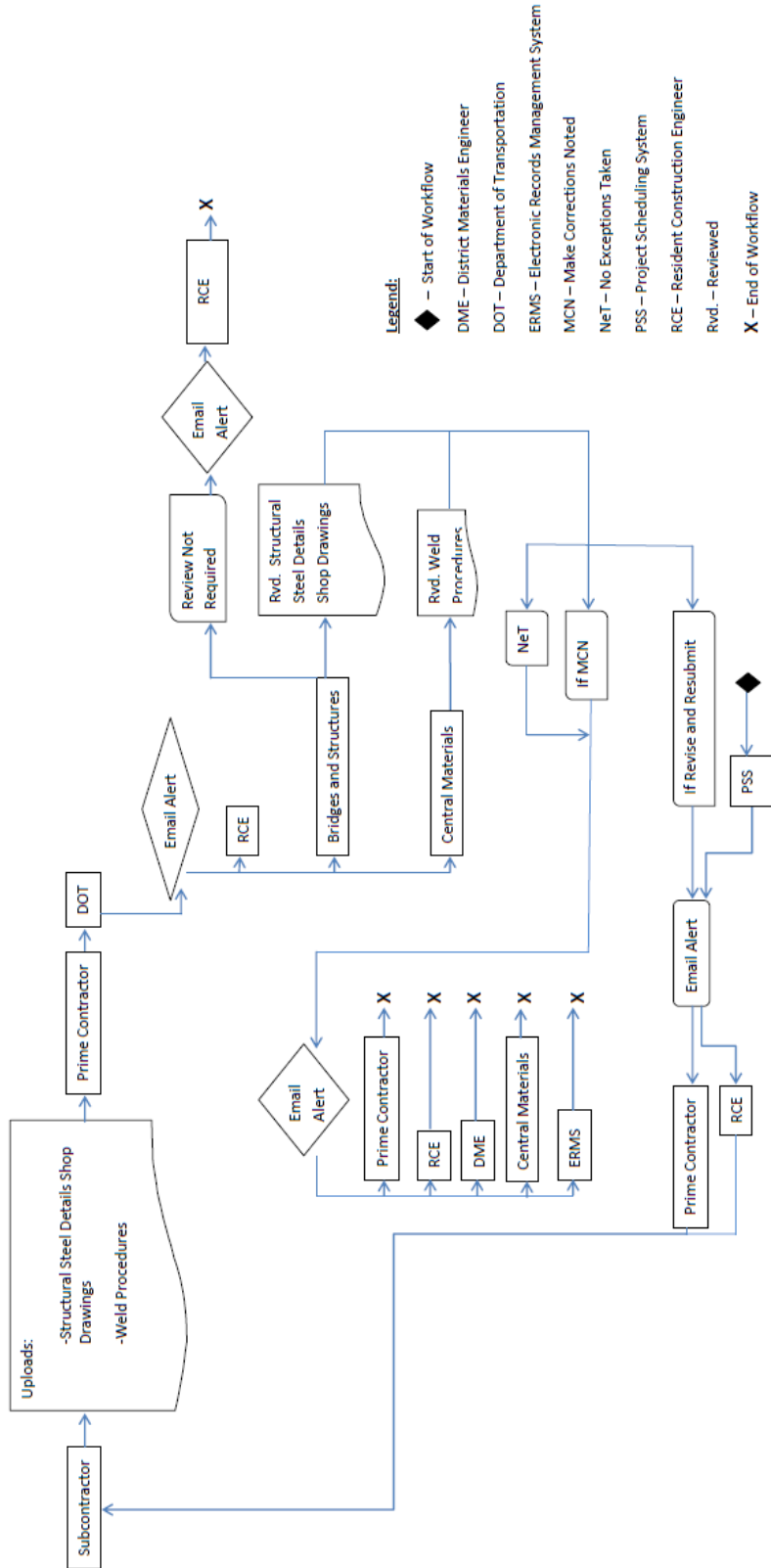
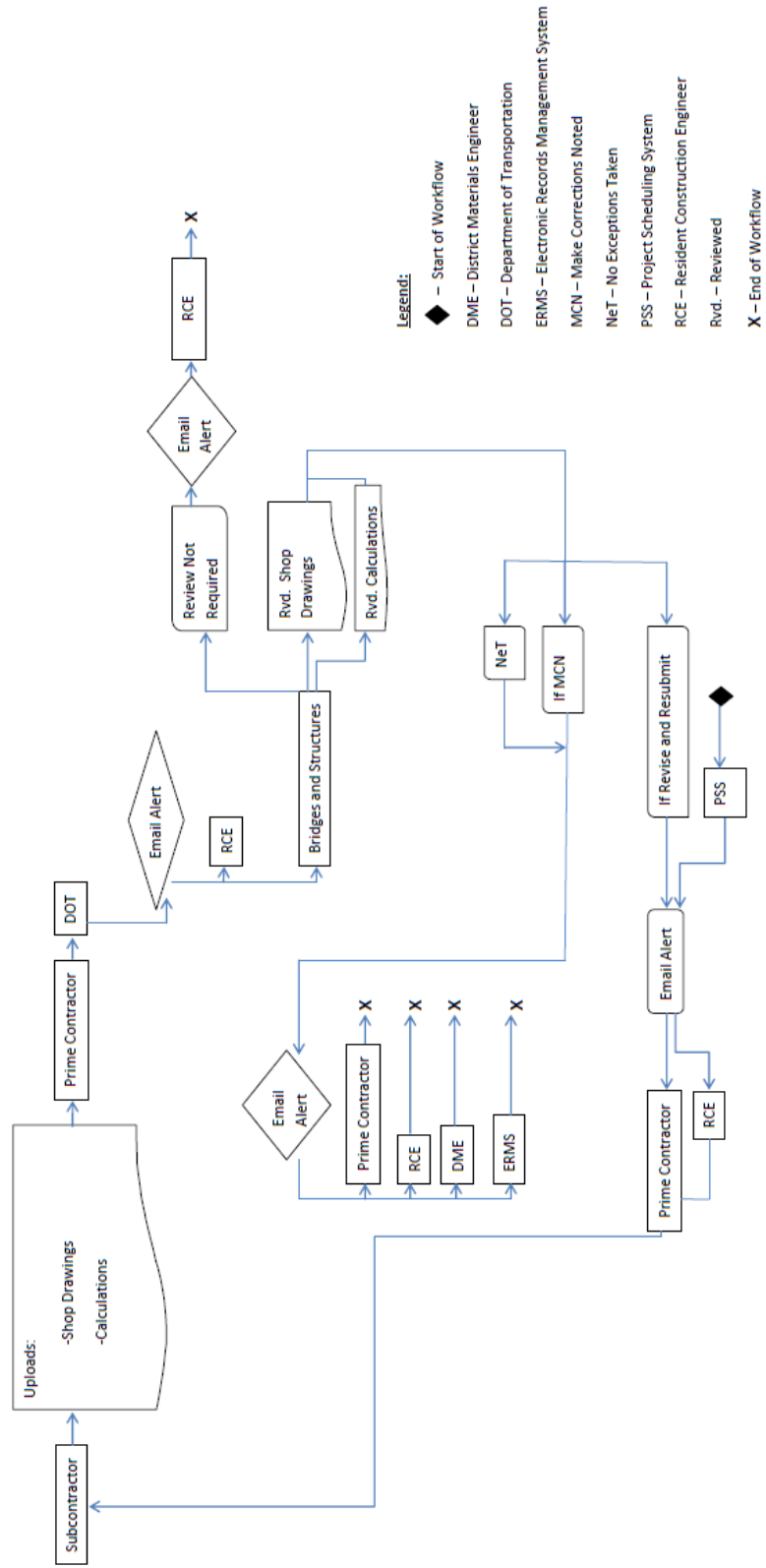


Figure B.4. Steel structures workflow

### Workflow: Detail Plans for Falsework or Centering Support of Steel Structures



**Figure B.5. Detail plans for falsework or centering support of steel structures workflow**

## Workflow: Steel and Aluminum Pedestrian Handrails

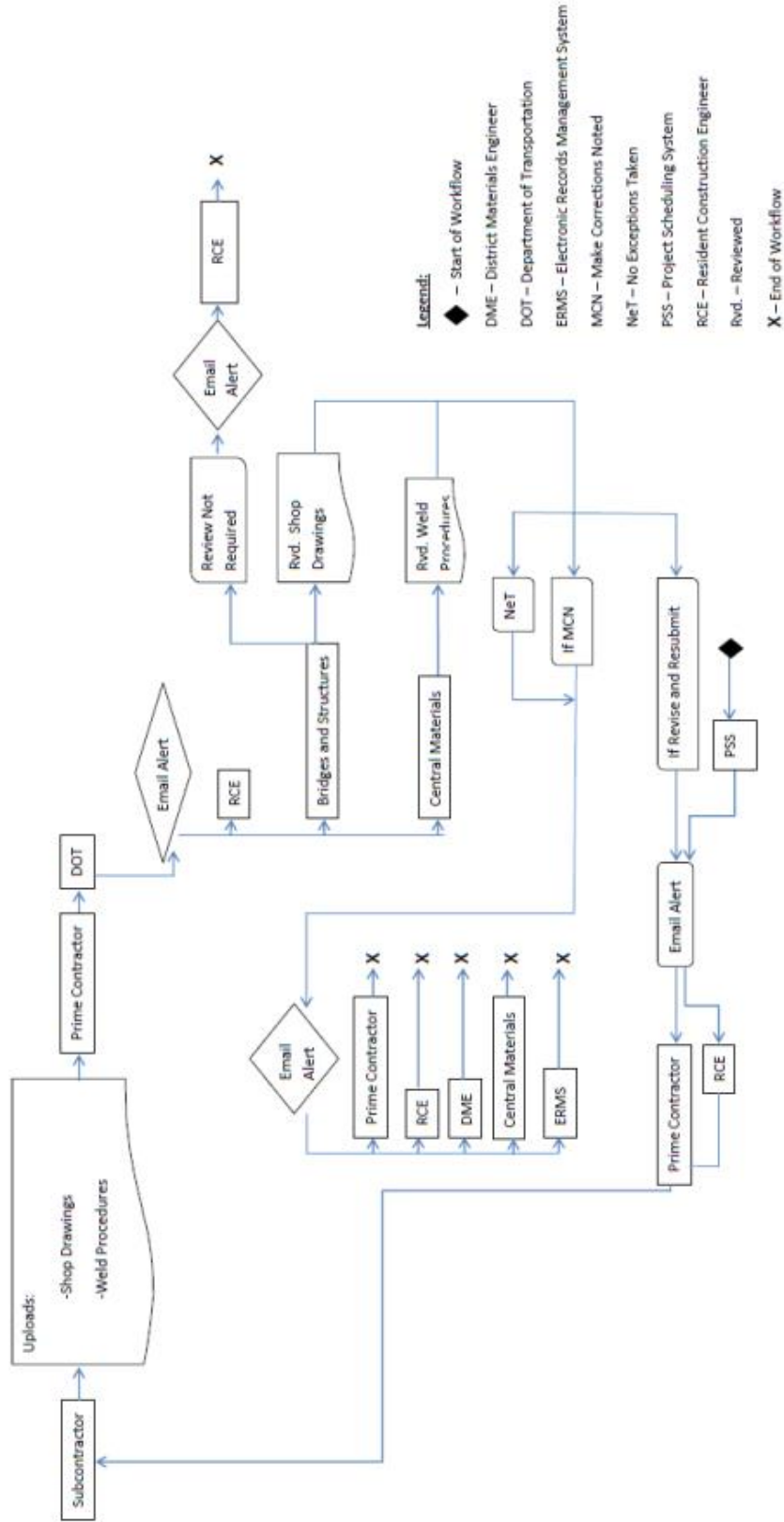
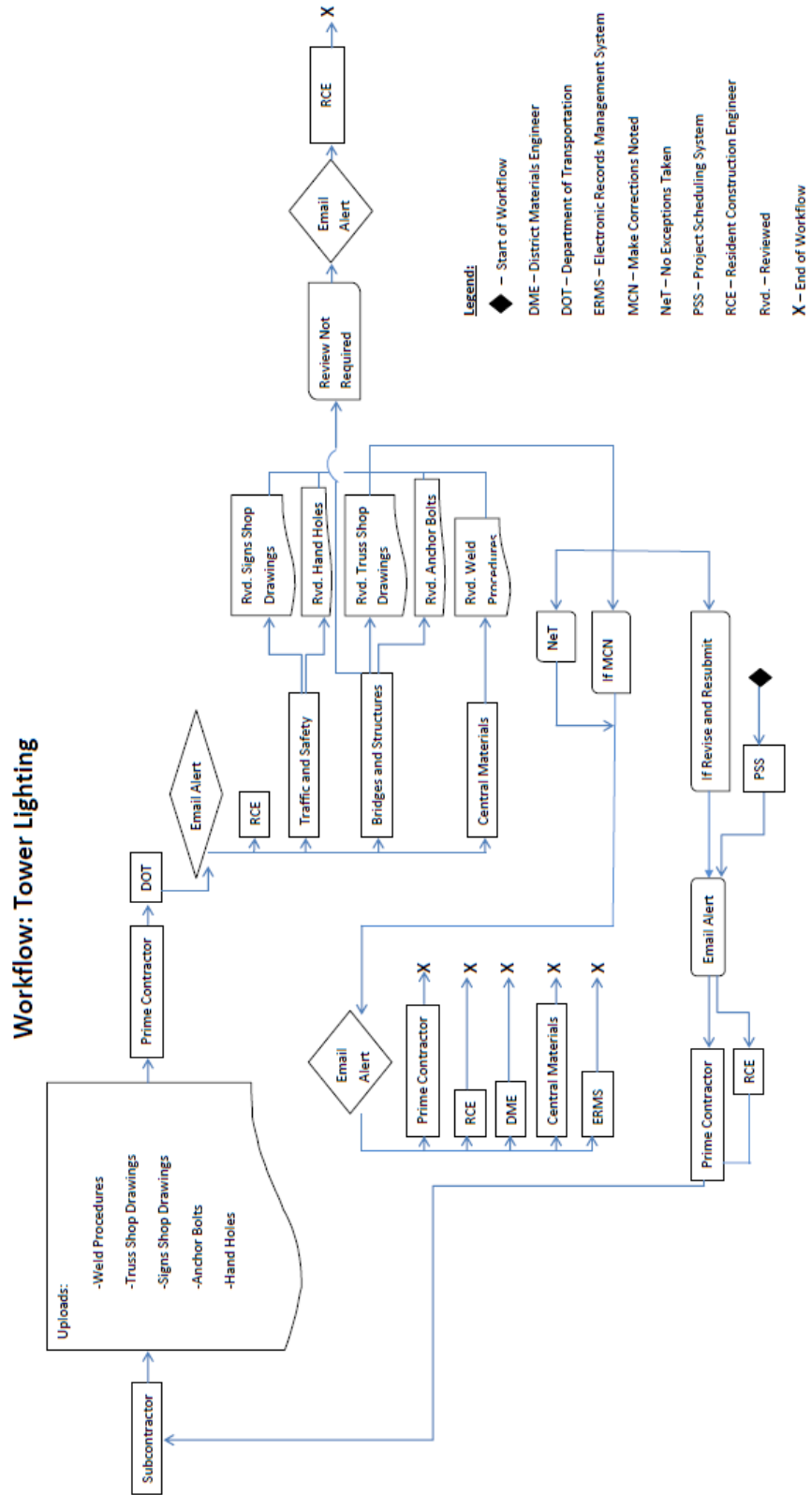


Figure B.6. Steel and aluminum pedestrian handrails workflow

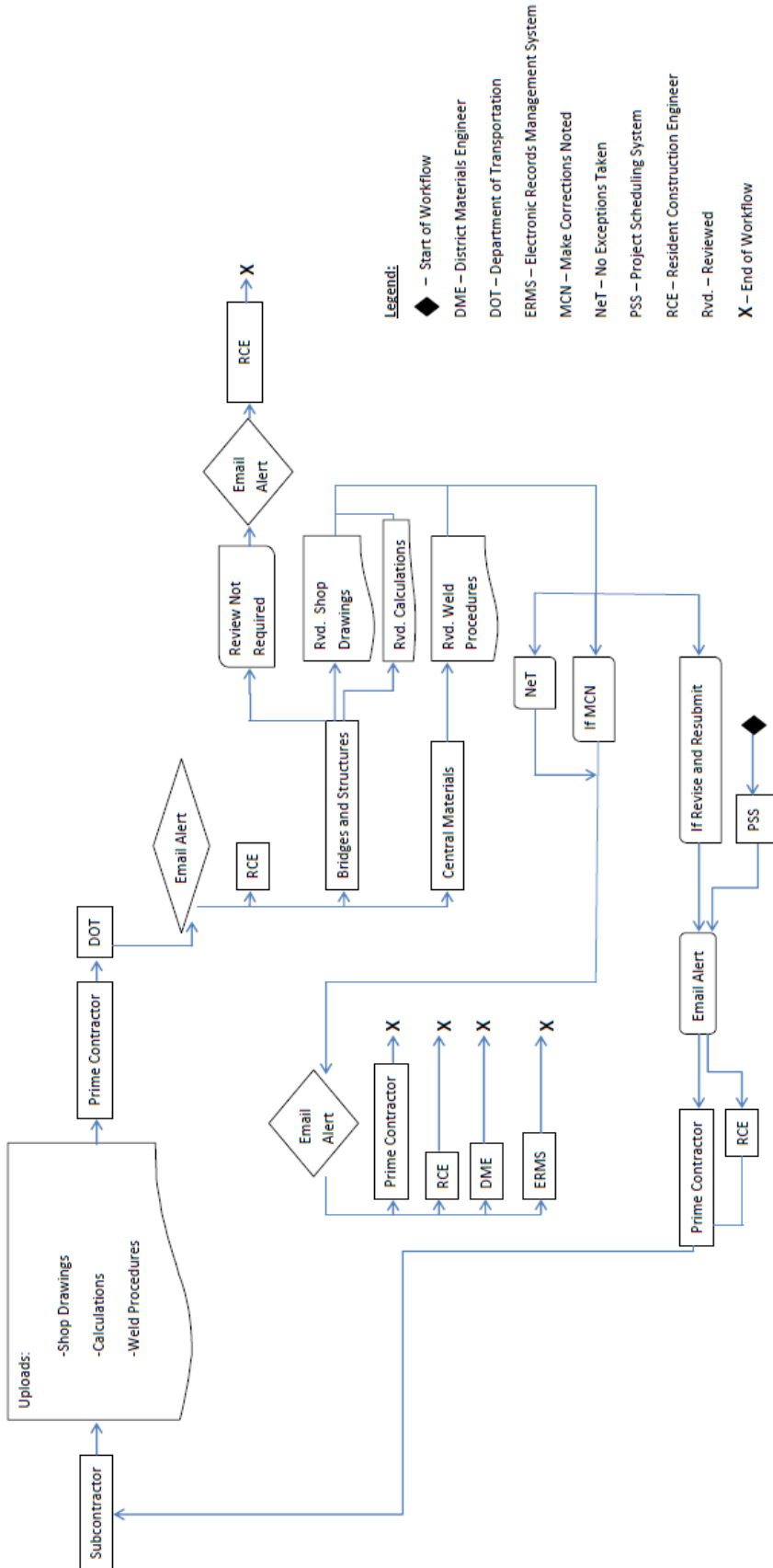




**Figure B.8. Tower lighting workflow**

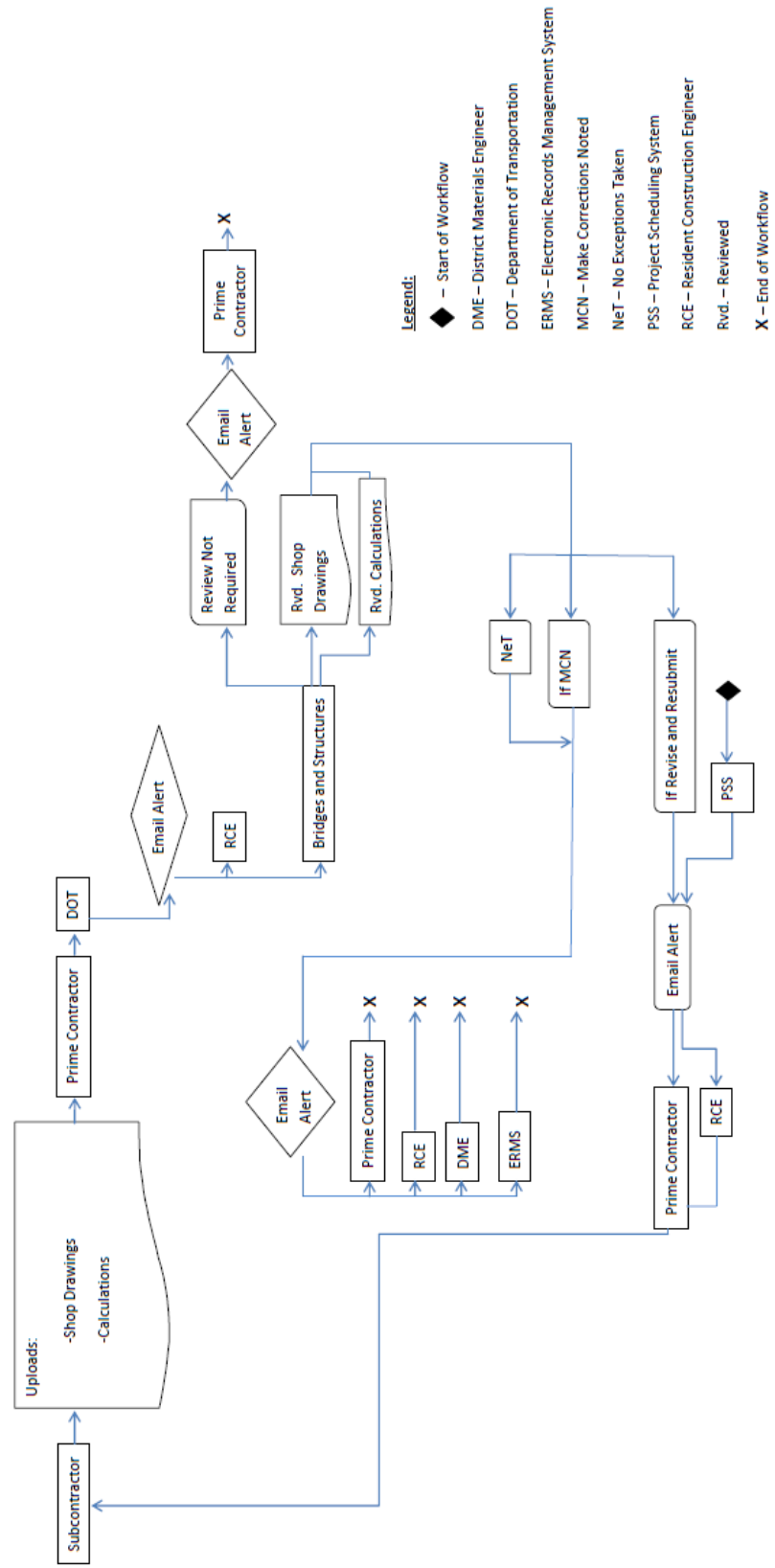


## Workflow: Bridge Components



**Figure B.9. Bridge components workflow**

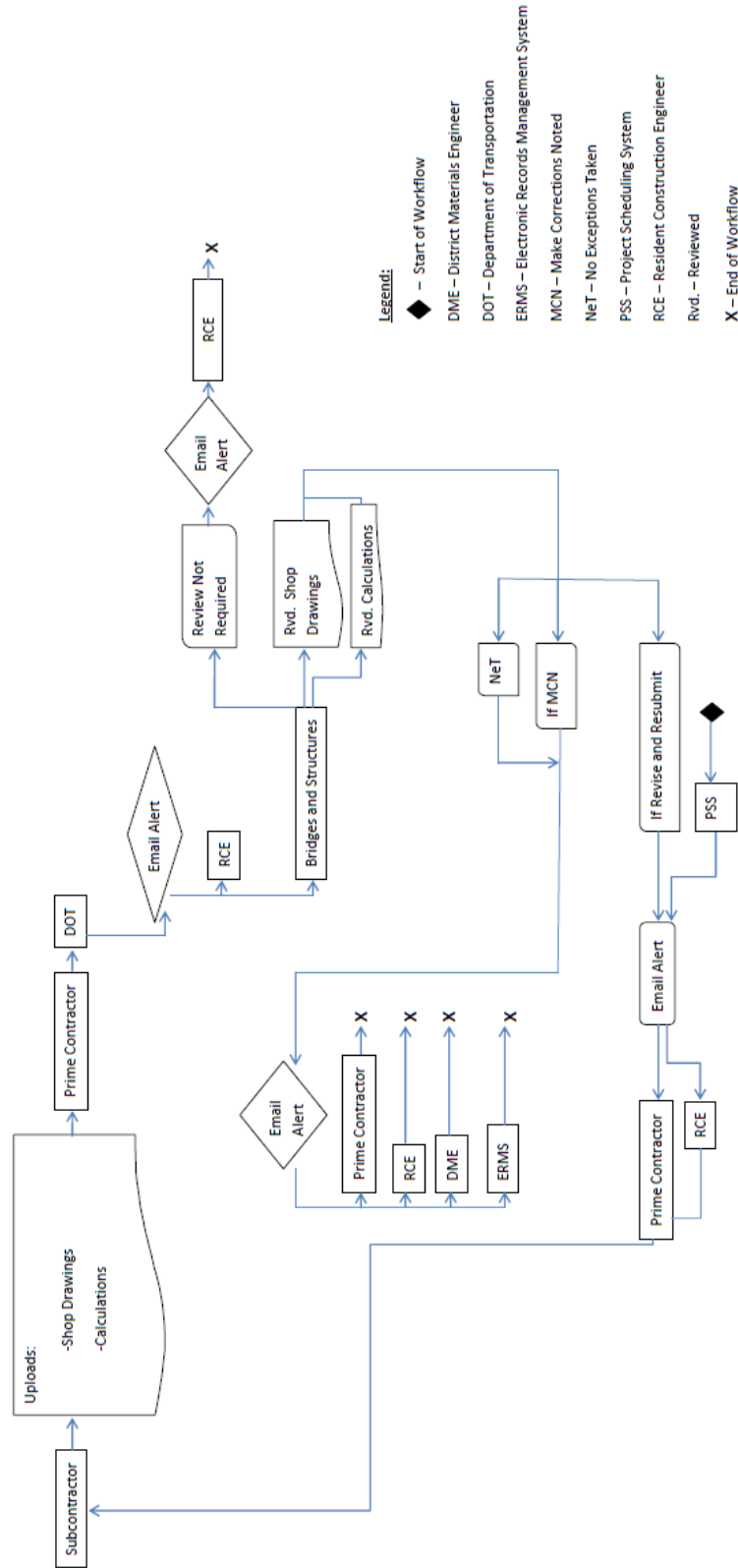
### Workflow: Pre-engineered Steel Truss Recreational Trail Bridge



**Figure B.10. Pre-engineered steel truss recreational trail bridge workflow**



## Workflow: Structural Erection Manual



- Legend:**
- ◆ – Start of Workflow
  - DME – District Materials Engineer
  - DOT – Department of Transportation
  - ERMS – Electronic Records Management System
  - MCN – Make Corrections Noted
  - NeT – No Exceptions Taken
  - PSS – Project Scheduling System
  - RCE – Resident Construction Engineer
  - Rvd. – Reviewed
  - X – End of Workflow

**Figure B.12. Structural erection manual workflow**

### Workflow: Temporary Shoring

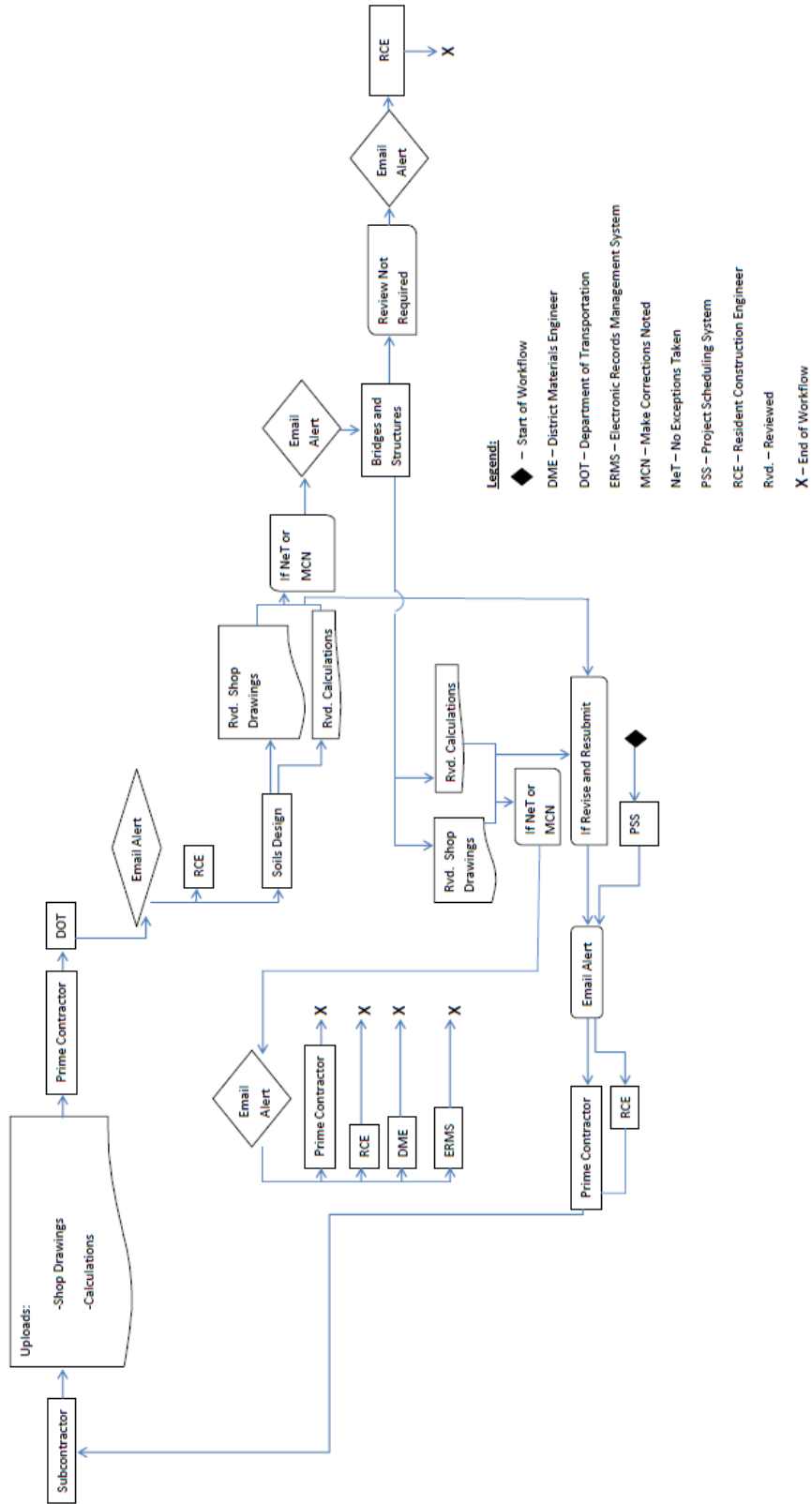


Figure B.13. Temporary shoring workflow

## Workflow: Temporary Sheet Pile Retaining Walls

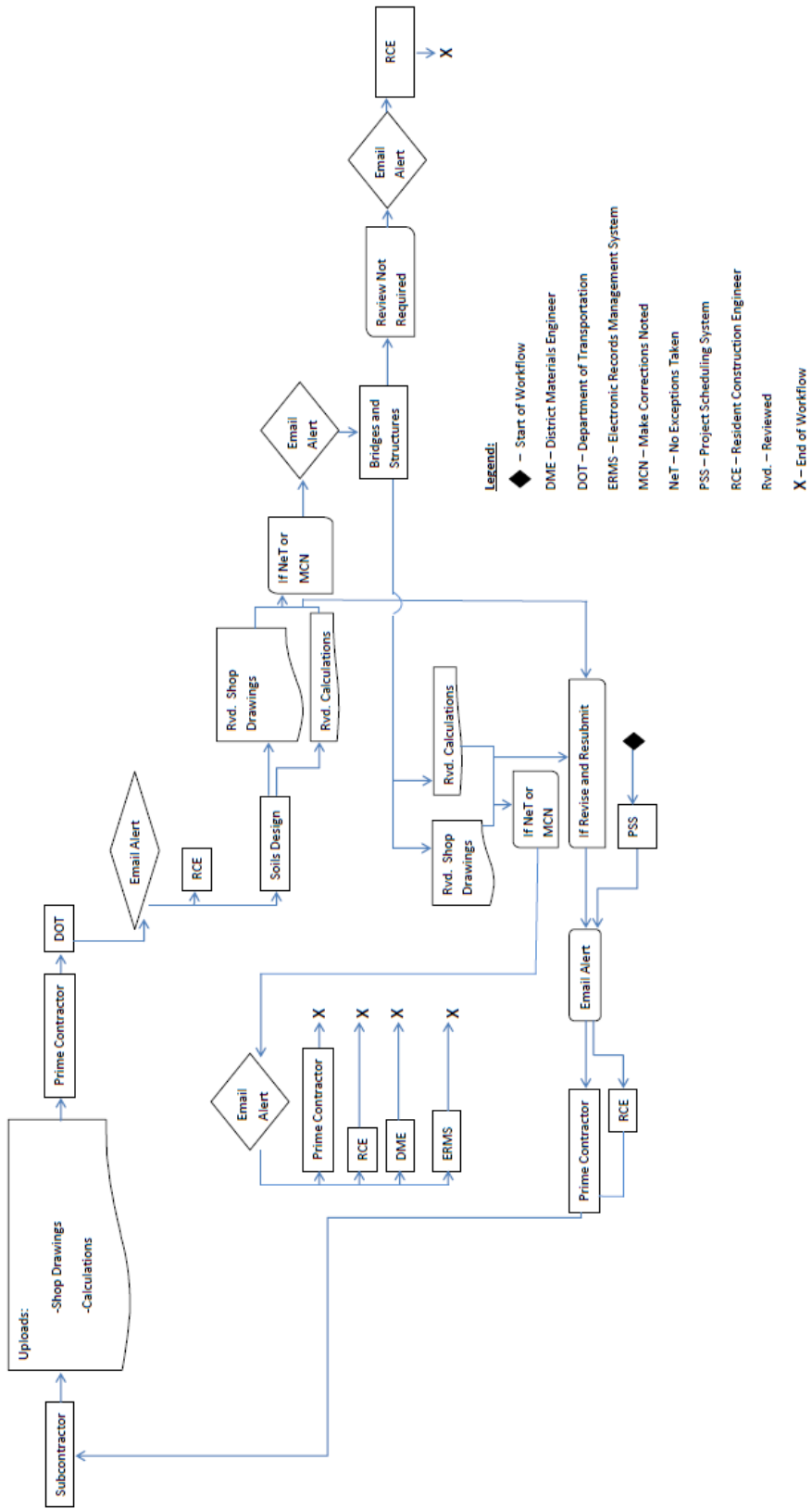
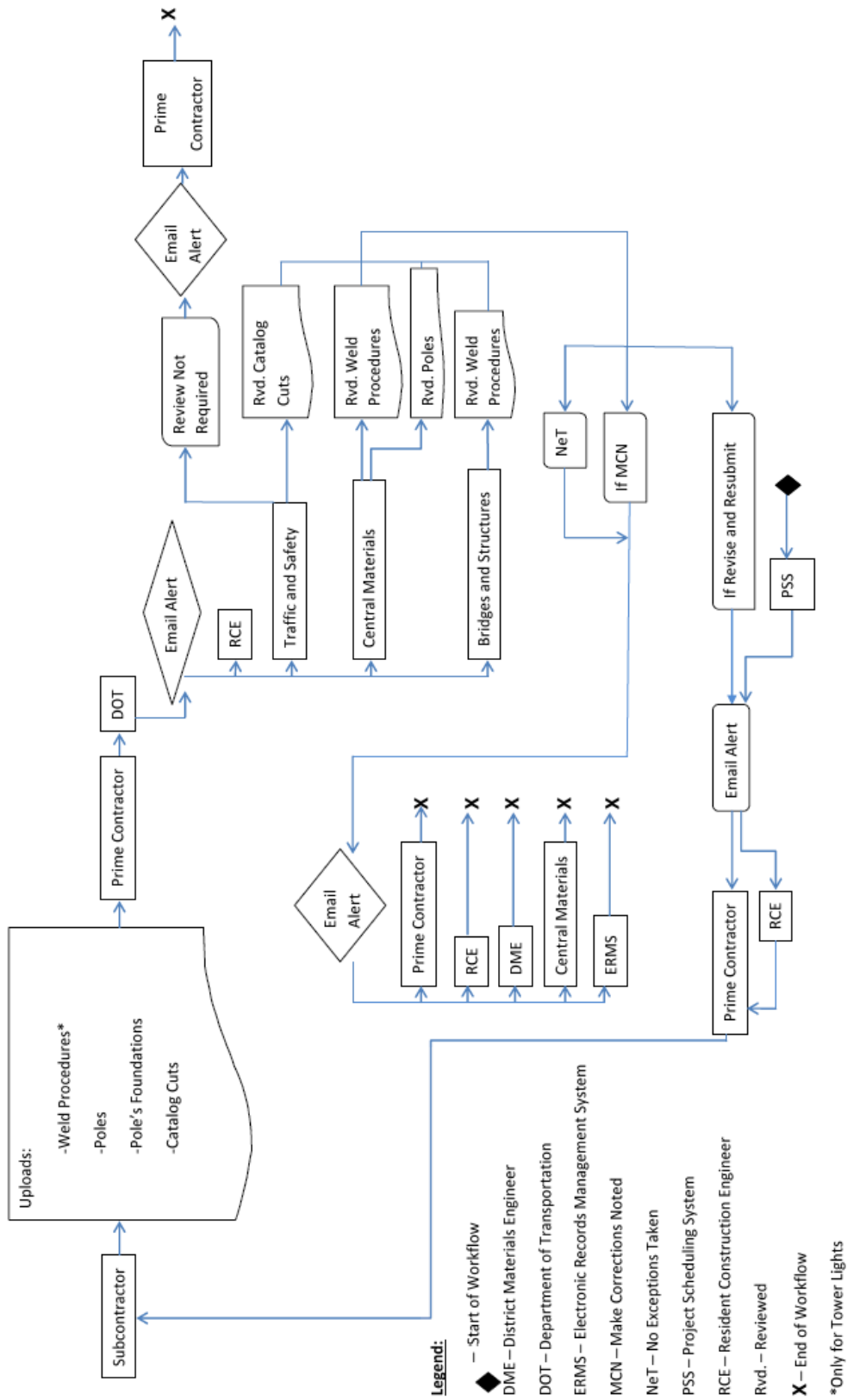


Figure B.14. Temporary sheet pile retaining walls workflow



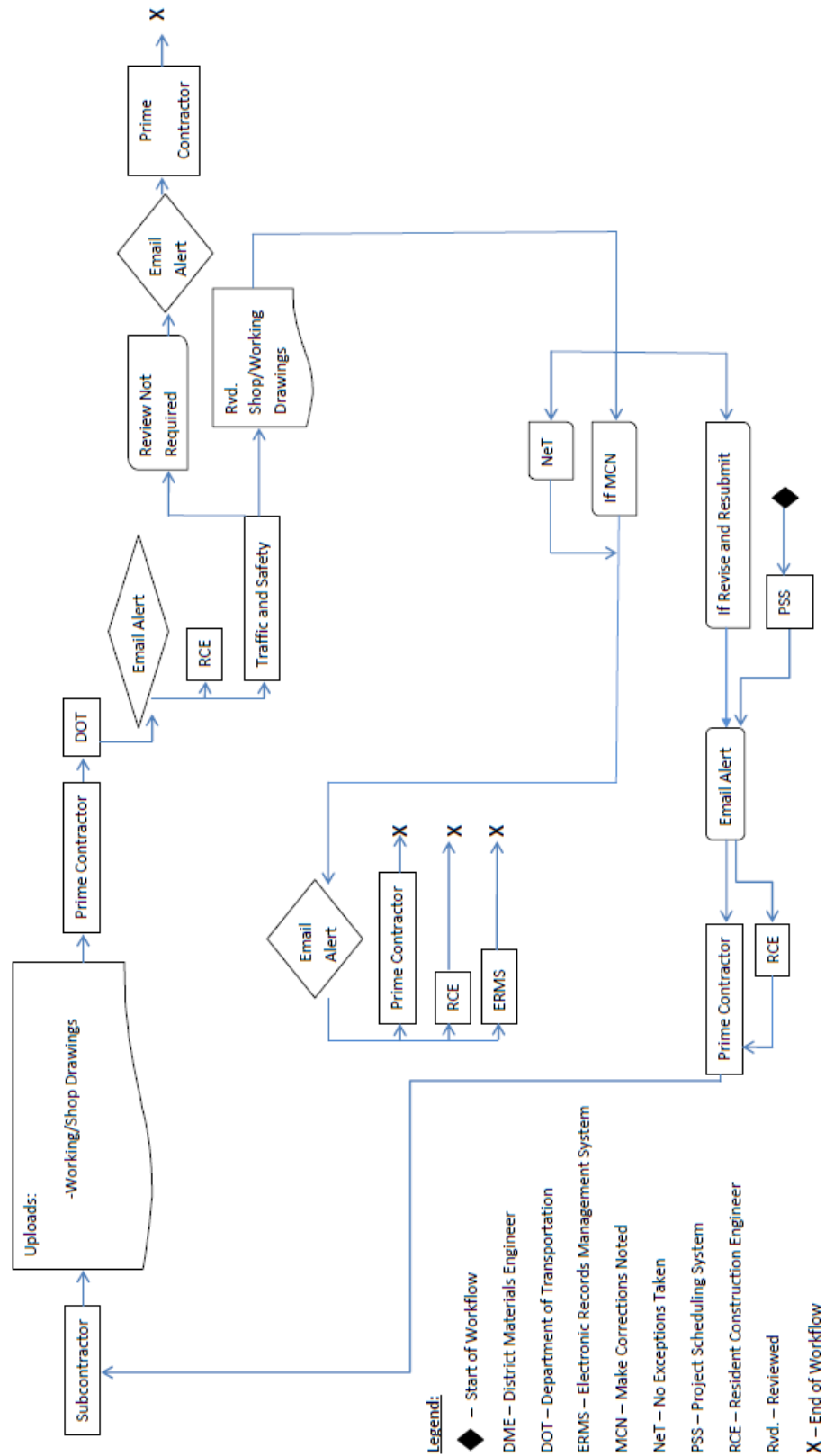
# Workflow: Highway Lighting



**Figure B.16. Highway lighting workflow**

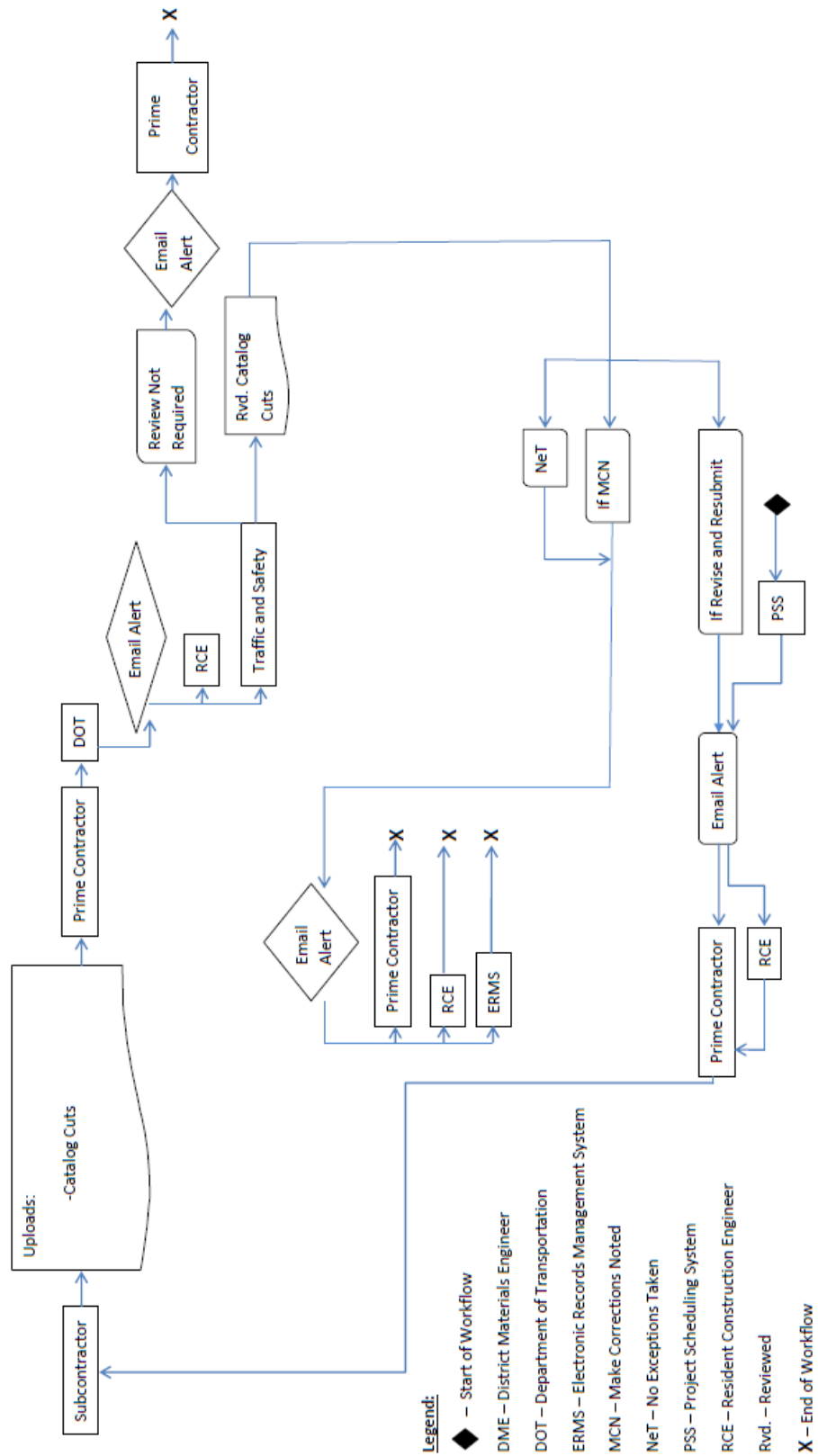


## Workflow: Highway Signing Steel Breakaways Posts



**Figure B.17. Highway signing steel breakaways posts workflow**

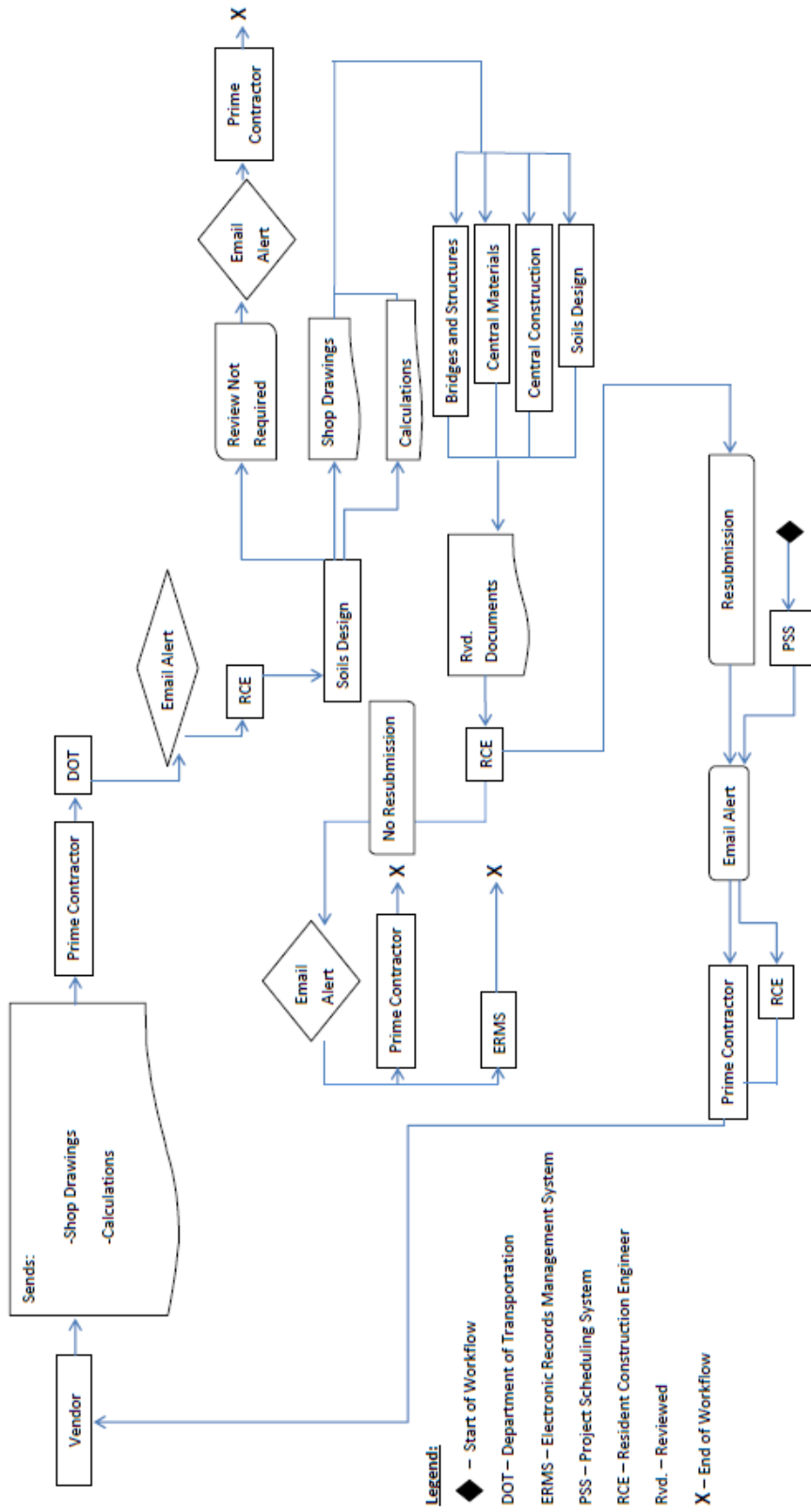
## Workflow: Traffic Signalization



**Figure B.18. Traffic signalization workflow**



**Workflow: MSE, segmental, & modular block retaining walls**



**Figure B.20. MSE, segmental and modular block retaining walls workflow**





### Workflow: Highway Sign Support Structures

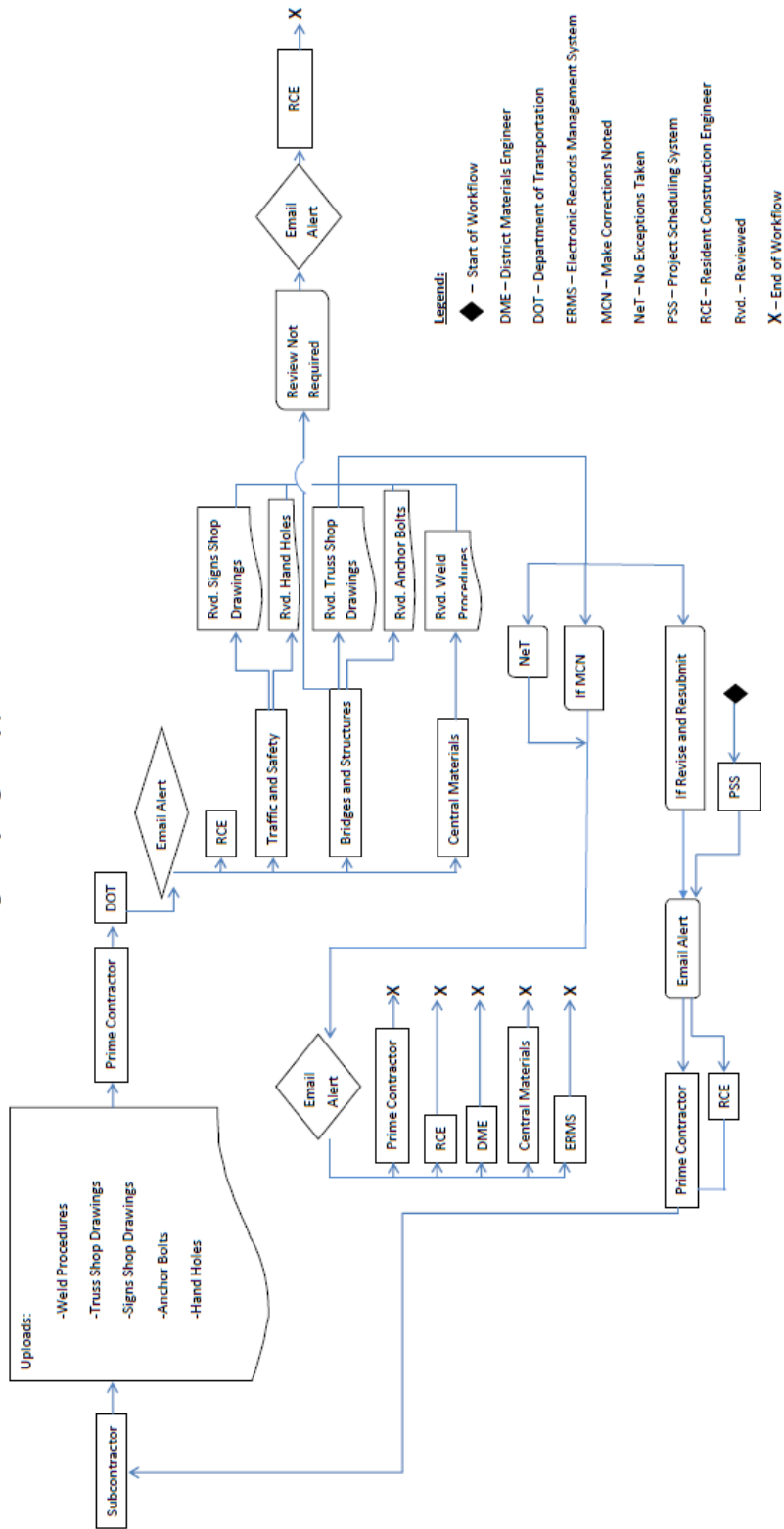


Figure B.23. Highway sign support structures workflow





## **APPENDIX C. REQUEST FOR INFORMATION WORKFLOWS BY FRANCIS O. DAYAMBA**

This appendix documents an investigation by Iowa State University, sponsored by and in partnership with the Iowa Department of Transportation (Iowa DOT), to identify the current workflow that can be followed once a request for information (RFI) has been submitted to the agency by a prime contractor. An RFI is typically initiated when the prime contractor, a subcontractor, or a supplier believes that they cannot implement their work as initially outlined in the contract documents. A representative of the contractor will then contact the resident construction engineer (RCE) with an RFI through the AEC-Sync software, and, with the help of experts employed by the Iowa DOT, the RCE will determine a resolution to the issue. Typically, the jobs that the Iowa DOT builds do not have a large number of RFIs. However, there are a few projects that have up to 70, and this can often be challenging to address.

If an RFI initiates in a contract modification, then the RFI becomes a request for change (RFC). The RFCs are considered when an additional contract amount is to be charged to the Iowa DOT for the following reasons: the scope of work is beyond what is stated in the contract, the project requires a large change of unit price quantities, a schedule change is required beyond the limits allowed in the contract documents, or the contractor wishes to value engineer an activity. If an RFC is to occur, the Iowa DOT will have named specific individuals that the RCE must contact in order to have the RFC to be approved. If the RFI does not become an RFC, then the RCE must use his/her experience to determine which department within the Iowa DOT has the expertise to recommend a response for the RFI. The various departments that are typically solicited for assisting are the Office of Design, Office of Construction, District Construction Engineer, and the District Material Engineer. Once the RCE discusses the issue with the Iowa DOT experts, then the RCE decides how to proceed. The Iowa DOT is yet to identify a specific workflow for how to address the RFIs. Prior to this investigation, the Iowa DOT has addressed each RFI on a case-by-case basis.

Throughout this investigation, the RFI archives of the US 6 over Broadway Viaduct Bridge replacement project and the Iowa Falls Arch Bridge were reviewed in an attempt to identify a typical workflow to follow when an RFI is submitted. In addition, a flow chart was developed to illustrate the process of how RCEs should proceed when an RFI or RFC is initiated. Our findings could potentially be adapted within the AEC-Sync or Sharepoint applications that are currently used by the Iowa DOT.

A benefit of this investigation for the Iowa DOT is that a typical workflow will be established for RFIs. This will be beneficial for all RCEs, particularly new RCEs, as they will better understand the procedures that must be followed. For complex projects many RFIs are submitted, so an established workflow will be especially valuable. Additionally, when a job is designed by a consulting engineer, often the consultant is requested to help resolve RFIs. However, there are some RFIs that can be resolved without the help of the consultant, which results in less time that the consultant will bill the Iowa DOT. Lastly, when an RCE receives an RFI and does not know who would be the best to help, he or she tends to send the RFI to more people than is necessary.

As a result, all these people must log into the AEC-Sync software, read the RFI, and determine that their feedback is not necessary. This is not the most productive use of the effort.

The Iowa Falls Arch Bridge and the Broadway Viaduct Bridge projects were chosen for this investigation because more than 50 RFIs were filed throughout the duration of the construction for each project. Most Iowa DOT projects have less than 5 RFIs.

## **Method**

The data from both projects that pertains to this investigation were downloaded and sorted in Microsoft Excel. The information that was collected for every RFI was the title, the final response provided to the contractor, and the individuals who contributed towards developing the response. Additionally, the research team wrote a brief summary that describes why the RFI was initiated. The data were then analyzed to identify trends to determine which group should usually be contacted when a particular type of RFI is processed.

## **Results**

Based on the RFIs that were initiated for both projects, the RFIs were categorized as follows:

- Discrepancy in quantity take-off
- Drawings submitted to confirm understanding of previously given instructions
- Determining how contract standards should be followed for specific cases
- Discrepancy in plans and specifications (omissions, conflicts, lack of detail, verifying details)
- Constructability use of means and methods to ease construction

These categories were formed because the research team found that RFIs within the same category have similar entities that resolved them (see Table C.1). Additionally, these categories are applicable to most construction projects that the Iowa DOT could pursue.

Table C.1 shows that the consulting engineer and the RCE always played a role in resolving all RFIs. The exception is an RFI that an RCE could resolve without assistance. Additionally, there are a number of RFIs that dealt with “means and methods,” where the Iowa DOT Structural Field Engineer (Wayne Sunday at the time that this investigation was conducted) did not provide technical knowledge but informed the RCE of the personnel within the Iowa DOT that can provide valuable input to resolve the RFI.

**Table C.1. Individuals involved in solving RFIs on two Iowa DOT projects**

<b>Category: Reason for RFI to occur</b>	<b>Parties involved to solve RFI</b>
Discrepancy in quantity take-off	Consulting engineer RCE
Drawings submitted to confirm understanding of previously given instructions	Consulting engineer RCE
Determining how contract standards should be followed for specific cases	Consulting engineer RCE
Discrepancy in plans and specifications (omissions, conflicts, lack of detail, verifying details)	Consulting engineer RCE Iowa DOT engineer–Varies depending on the RFI
Constructability, use of means and methods to ease construction	Consulting engineer Iowa DOT engineer RCE

Note: The Iowa DOT Bridge Construction Engineer (Wayne Sunday at the time this investigation was conducted) provided assistance in determining who within the DOT can help resolve the RFI.

Upon discussing the findings with personnel from the Iowa DOT that had experience working with RFIs, the research team recommended that changes should be made to better show the people involved in solving the RFI (see Figure C.1).

The Iowa Falls Arch Bridge project and Broadway Viaduct Bridge project were both designed by consultants. Approximately two-thirds of Iowa DOT projects are designed by Iowa DOT engineers, and the rest are designed by consultants. It is important for projects that are designed in-house to follow a different process than that used for projects designed by an external party. If designed in-house, all RFIs must be reported to the Office of Bridge and Structures. If a consultant designs the project, the consultant coordinator and the structural field engineer should be the first people to review the RFI. If they cannot resolve the RFI, the RFI is then forwarded to the designer and to any other department staff within the Iowa DOT who can provide value in resolving it. On the bottom right corner of Figure C.1, there is a “Project Staff Chart” that outlines all the Iowa DOT Engineers that could participate in resolving an RFI.

### **Limitations**

Both of the projects analyzed during this investigation were designed by consulting engineers. Because the majority of the projects built by the Iowa DOT are designed by Iowa DOT engineers in-house, there could have been value to studying a project designed in-house. However, the majority of the projects designed in-house are less complex than those designed by consultants, so there are very few RFIs. This circumstance makes the previously described limitation less problematic.

The individuals who post comments in AEC-Sync are only labeled by the organization that they are representing. Because their positions and departments are not identified, in order to establish

the flowchart within these organizations, researchers had to work closely with Iowa DOT. As a result, the first draft of the workflow produced by the project team did not provide specific positions to contact for the RCE.

The communication that was analyzed is only information that is documented by the AEC-Sync software, and that constraint limits the extent to which the findings can be generalized. However, the workflow depicted in Figure C.1 was developed after interviews with the Iowa DOT Structure Field Engineer.

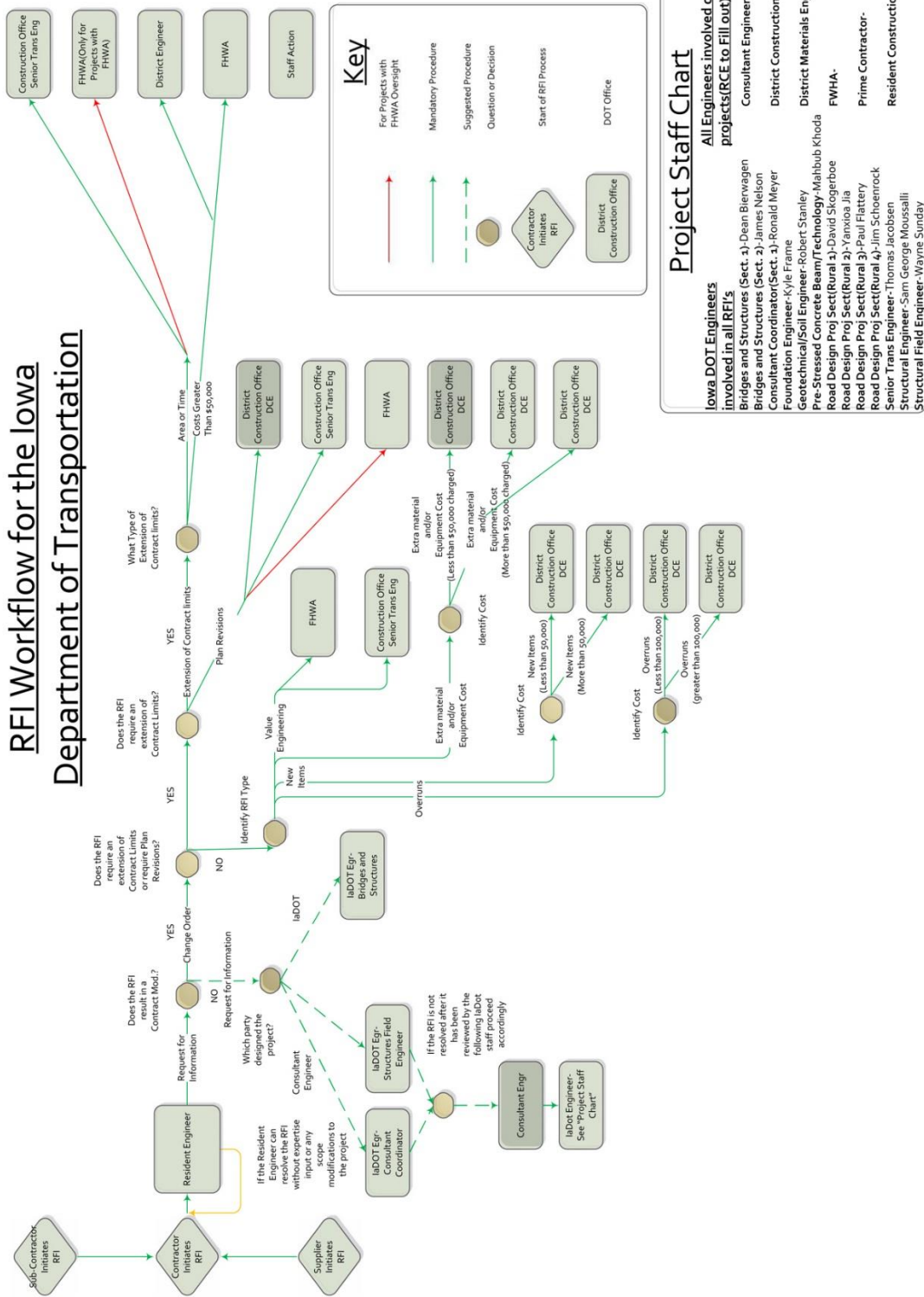


Figure C.1. RFI Workflow for the Iowa DOT